



An Oshkosh Corporation Company

---

# ***Operation and Safety Manual***

*Original Instructions - Keep this manual with the machine at all times.*

***Models***

***R2632***

***R3246***

***PVC 1910***

---

**ANSI**   **AS/NZS GB**

**31215090**  
October 4, 2019 - Rev B



## **WARNING**

Operating, servicing and maintaining this vehicle or equipment can expose you to chemicals including engine exhaust, carbon monoxide, phthalates, and lead, which are known to the State of California to cause cancer and birth defects or other reproductive harm. To minimize exposure, avoid breathing exhaust, do not idle the engine except as necessary, service your vehicle or equipment in a well-ventilated area and wear gloves or wash your hands frequently when servicing. For more information go to [www.P65Warnings.ca.gov](http://www.P65Warnings.ca.gov).

## **FOREWORD**

The Mobile Elevating Work Platform (MEWP) models covered in this manual are designed and tested to meet or exceed various compliance standards. Please refer to the manufacturer's nameplate affixed to the subject MEWP for specific standard compliance information.

This manual is a very important tool! Keep it with the machine at all times.

The purpose of this manual is to provide owners, users, operators, lessors, and lessees with the precautions and operating procedures essential for the safe and proper machine operation for its intended purpose.

Due to continuous product improvements, JLG Industries, Inc. reserves the right to make specification changes without prior notification. Contact JLG Industries, Inc. for updated information.

Refer to [www.JLG.com](http://www.JLG.com) for Warranty, Product Registration, and other machine-related documentation.

## **SAFETY ALERT SYMBOLS AND SAFETY SIGNAL WORDS**



**THIS IS THE SAFETY ALERT SYMBOL. IT IS USED TO ALERT YOU TO THE POTENTIAL PERSONAL INJURY HAZARDS. OBEY ALL SAFETY MESSAGES THAT FOLLOW THIS SYMBOL TO AVOID POSSIBLE INJURY OR DEATH.**

### **⚠ DANGER**

**INDICATES AN IMMINENTLY HAZARDOUS SITUATION. IF NOT AVOIDED, WILL RESULT IN SERIOUS INJURY OR DEATH. THIS DECAL WILL HAVE A RED BACKGROUND.**

### **⚠ WARNING**

**INDICATES A POTENTIALITY HAZARDOUS SITUATION. IF NOT AVOIDED, COULD RESULT IN SERIOUS INJURY OR DEATH. THIS DECAL WILL HAVE AN ORANGE BACKGROUND.**

### **⚠ CAUTION**

**INDICATES A POTENTIALITY HAZARDOUS SITUATION. IF NOT AVOIDED, MAY RESULT IN MINOR OR MODERATE INJURY. IT MAY ALSO ALERT AGAINST UNSAFE PRACTICES. THIS DECAL WILL HAVE A YELLOW BACKGROUND.**

### **NOTICE**

**INDICATES INFORMATION OR A COMPANY POLICY THAT RELATES DIRECTLY OR INDIRECTLY TO THE SAFETY OF PERSONNEL OR PROTECTION OF PROPERTY.**

**⚠ WARNING**

**THIS PRODUCT MUST COMPLY WITH ALL SAFETY RELATED BULLETINS. CONTACT JLG INDUSTRIES, INC. OR THE LOCAL AUTHORIZED JLG REPRESENTATIVE FOR INFORMATION REGARDING SAFETY RELATED BULLETINS WHICH MAY HAVE BEEN ISSUED FOR THIS PRODUCT.**

**NOTICE**

**JLG INDUSTRIES, INC. SENDS SAFETY RELATED BULLETINS TO THE OWNER OF RECORD OF THIS MACHINE. CONTACT JLG INDUSTRIES, INC. TO ENSURE THAT THE CURRENT OWNER RECORDS ARE UPDATED AND ACCURATE.**

**NOTICE**

**JLG INDUSTRIES, INC. MUST BE NOTIFIED IMMEDIATELY IN ALL INSTANCES WHERE JLG PRODUCTS HAVE BEEN INVOLVED IN AN ACCIDENT INVOLVING BODILY INJURY OR DEATH OR WHEN SUBSTANTIAL DAMAGE HAS OCCURRED TO PERSONAL PROPERTY OR THE JLG PRODUCT.**

**For:**

- Accident Reporting
- Product Safety Publications
- Current Owner Updates
- Questions Regarding Product Safety
- Standards and Regulations Compliance Information
- Questions Regarding Special Product Applications
- Questions Regarding Product Modifications

**Contact:**

Product Safety and Reliability Department  
JLG Industries, Inc.  
13224 Fountainhead Plaza  
Hagerstown, MD 21742  
USA

or Your Local JLG Office  
(See addresses on manual rear cover)

**In USA:**

Toll Free: 877-JLG-SAFE (877-554-7233)

**Outside USA:**

Phone: 240-420-2661  
E-mail: ProductSafety@JLG.com

**REVISION LOG**

Original Issue - A ..... August 29, 2019

Revision - B ..... October 4, 2019

## TABLE OF CONTENTS

### SECTION - 1 - SAFETY PRECAUTIONS

1.1	GENERAL	1-1
1.2	PRE-OPERATION	1-1
	Operator Training and Knowledge	1-1
	Workplace Inspection	1-2
	Machine Inspection	1-2
1.3	OPERATION	1-3
	General	1-3
	Trip and Fall Hazards	1-4
	Electrocution Hazards	1-5
	Tipping Hazards	1-6
	Crushing and Collision Hazards	1-9
1.4	TOWING, LIFTING, AND HAULING	1-10
1.5	MAINTENANCE	1-10
	Maintenance Hazards	1-10
	Battery Hazards	1-11

### SECTION - 2 - USER RESPONSIBILITIES, MACHINE PREPARATION, AND INSPECTION

2.1	PERSONNEL TRAINING	2-1
	Operator Training	2-1
	Training Supervision	2-1
	Operator	2-1
	Machine Familiarization	2-2
2.2	PREPARATION, INSPECTION, AND MAINTENANCE	2-2
	Inspection and Maintenance Table	2-3

2.3	PRE-START INSPECTION	2-4
2.4	WALK-AROUND INSPECTION	2-6
	Inspection Diagram	2-7
2.5	FUNCTION CHECK	2-8

### SECTION - 3 - MACHINE CONTROLS, INDICATORS, AND OPERATION

3.1	GENERAL	3-1
3.2	DESCRIPTION	3-1
3.3	OPERATING CHARACTERISTICS AND LIMITATIONS	3-2
	Placards	3-2
	Capacities	3-2
	Stability	3-2
3.4	PLATFORM LOADING	3-2
3.5	BATTERY CHARGING	3-3
3.6	MACHINE CONTROL LOCATIONS	3-4
3.7	GROUND CONTROL CONSOLE	3-5
	Ground/Platform/OFF Key Selector Switch	3-6
	Platform Lift/Lower Switch	3-6
	Inverter ON/OFF Switch (If Equipped)	3-6
	Ground Emergency Stop Switch	3-7
	Hourmeter	3-7
	Overload Indicator (LSS)	3-7
	MDI Indicator (If Equipped)	3-8
3.8	PLATFORM CONTROL STATION	3-9
	Emergency Stop Switch	3-10

## TABLE OF CONTENTS

Lift/Drive Selector Switch .....	3-10	3.14 MACHINE LIFTING AND TIE DOWN .....	3-23
Forward/Reverse/Lift/Lower Directional Arrow .....	3-10	3.15 TOWING.....	3-25
Drive/Lift/Steer Joystick Control.....	3-11	Hydraulic Brake Release.....	3-25
Steering and Traveling.....	3-11	Push Button Brake Release (AUS Market Only) .....	3-26
Steering.....	3-12		
Traveling Forward and Reverse.....	3-12	<b>SECTION - 4 - EMERGENCY PROCEDURES</b>	
Raising And Lowering Platform .....	3-12	4.1 GENERAL INFORMATION.....	4-1
Arm Guards (If Equipped) .....	3-12	4.2 INCIDENT NOTIFICATION .....	4-1
Overload Indicator (LSS) .....	3-13	4.3 EMERGENCY OPERATION .....	4-2
Tilt Indicator Warning Light and Alarm .....	3-13	Operator Unable to Control Machine.....	4-2
Variable Tilt - Platform Restricted Height Indicator ....	3-13	Righting of Tipped Machine.....	4-2
Horn .....	3-13	Platform Caught Overhead.....	4-2
Alarm .....	3-13	4.4 PLATFORM MANUAL DESCENT.....	4-3
Battery Charge Indicator.....	3-14		
System Fault Indicator .....	3-14	<b>SECTION - 5 - ACCESSORIES</b>	
Indoor/Outdoor Operation Indicator .....	3-14	5.1 AVAILABLE ACCESSORIES.....	5-1
Indoor/Outdoor Operation Mode Switch .....	3-14	5.2 OPTIONS/ACCESSORIES RELATIONSHIP TABLE.....	5-2
Low/High Drive Speed.....	3-14	5.3 DC/AC POWER INVERTER .....	5-3
3.9 GRADE AND SIDESLOPE.....	3-15	Specifications .....	5-3
3.10 PLATFORM EXTENSION .....	3-16	Safety Precautions.....	5-3
3.11 PLATFORM RAILS FOLD-DOWN PROCEDURE		Preparation and Inspection .....	5-4
(IF EQUIPPED) .....	3-17	Operation .....	5-4
Platform with Rail-in-Rail Extension Deck .....	3-17	5.4 PIPE RACKS.....	5-4
Platform with Dual Rails Extension Deck.....	3-19	Safety Precautions.....	5-5
3.12 PLATFORM MANUAL DESCENT.....	3-21	Preparation and Inspection .....	5-5
3.13 PARKING AND STOWING MACHINE.....	3-22	Operation .....	5-5



## TABLE OF CONTENTS

5.5	ANTI-VANDALISM PACKAGE.....	5-6	Eagle Performance.....	6-6
5.6	RAIL-MOUNTED PLATFORM EXTENSION HANDLES.....	5-7	Green Power (China (GB) Only).....	6-7
	Operation.....	5-7	6.5 LUBRICATION.....	6-7
5.7	FOOTSWITCH.....	5-8	Capacities.....	6-7
	Operation.....	5-8	Specifications.....	6-7
5.8	MAGNETIC GATE LATCH.....	5-8	Hydraulic Oil Operating Temperature Chart.....	6-8
5.9	JLG™ MOBILE CONTROL.....	5-9	6.6 OPERATOR MAINTENANCE.....	6-9
	Download.....	5-9	Engaging the Safety Prop.....	6-9
	Operation.....	5-10	Hydraulic Oil Check Procedure.....	6-10
	Document Resources.....	5-10	Battery Maintenance and Safety Practices.....	6-11
			Battery Quick-Disconnect.....	6-11
<b>SECTION - 6 - SPECIFICATIONS AND OPERATOR MAINTENANCE</b>			6.7 TIRE WEAR AND DAMAGE.....	6-12
6.1	GENERAL INFORMATION.....	6-1	Wheel and Tire Replacement.....	6-12
	Other Publications Available Specific to this Machine ..	6-1	Wheel Installation.....	6-13
	Serial Number Identification.....	6-1	6.8 DECAL INSTALLATION.....	6-14
6.2	SUPPLEMENTAL INFORMATION.....	6-2	Diagram.....	6-14
6.3	MACHINE SPECIFICATIONS.....	6-2	Decals.....	6-16
	Operating Specifications.....	6-2	6.9 DIAGNOSTIC TROUBLE CODES (DTC).....	6-18
	Machine Dimensions.....	6-3		
	Maximum Allowable Operating Slope.....	6-3		
	Platform Capacities.....	6-3		
	Tires.....	6-4		
	Batteries.....	6-4		
6.4	BATTERY CHARGER.....	6-5		
	Specifications.....	6-5		
	Delta-Q.....	6-6		

## SECTION - 7 - INSPECTION AND REPAIR LOG

## ***TABLE OF CONTENTS***

---

## SECTION 1. SAFETY PRECAUTIONS

### 1.1 GENERAL

This section outlines the necessary precautions for proper and safe machine usage and maintenance. In order to promote proper machine usage, it is mandatory that a daily routine is established based on the content of this manual. A maintenance program, using the information provided in this manual and the Service and Maintenance Manual, must also be established by a qualified person and must be followed to ensure that the machine is safe to operate.

The owner/user/operator/lessor/lessee of the machine must not accept operating responsibility until this manual has been read, training is accomplished, and operation of the machine has been completed under the supervision of an experienced and qualified operator.

These sections contain the responsibilities of the owner, user, operator, lessor, and lessee concerning safety, training, inspection, maintenance, application, and operation. If there are any questions with regard to safety, training, inspection, maintenance, application, and operation, please contact JLG Industries, Inc. ("JLG").

#### **WARNING**

**FAILURE TO COMPLY WITH THE SAFETY PRECAUTIONS LISTED IN THIS MANUAL COULD RESULT IN MACHINE DAMAGE, PROPERTY DAMAGE, PERSONAL INJURY OR DEATH.**

### 1.2 PRE-OPERATION

#### Operator Training and Knowledge

- Read, understand, and study the Operation and Safety Manual in its entirety before operating the machine. For clarification, questions, or additional information regarding any portions of this manual, contact JLG Industries, Inc.

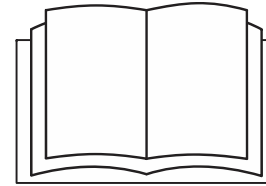

- Only personnel who have received proper training regarding the inspection, application and operation of MEWPs (including recognition and avoiding hazards associated with their operation) shall be authorized to operate a MEWP.
- Only properly trained personnel who have received unit-specific familiarization shall operate a MEWP. The user shall determine if personnel are qualified to operate the MEWP prior to operation.
- Read, understand, and obey all DANGERS, WARNINGS, CAUTIONS, and operating instructions on the machine and in this manual.
- Ensure that the machine is to be used in a manner which is within the scope of its intended application as determined by JLG.

## SECTION 1 - SAFETY PRECAUTIONS

---

- All operating personnel must have a thorough understanding of the intended purpose and function of the MEWP controls, including platform, ground and emergency descent controls.
- Read, understand, and obey all applicable employer, local, and governmental regulations as they pertain to your utilization and application of the machine.

### Workplace Inspection

- Precautions to avoid all hazards in the work area must be taken by the user before and during operation of the machine.
- Do not operate or raise the platform from a position on trucks, trailers, railway cars, floating vessels, scaffolds or other equipment unless the application is approved in writing by JLG.
- Before operation, check work area for overhead hazards such as electric lines, bridge cranes, and other potential overhead obstructions.
- Check operating surfaces for holes, bumps, drop-offs, obstructions, debris, concealed holes, and other potential hazards.
- Check the work area for hazardous locations. Do not operate the machine in hazardous environments unless approved for that purpose by JLG.
- Ensure that the ground conditions are adequate to support the maximum tire load indicated on the tire load decals located on the chassis adjacent to each wheel.
- This machine can be operated in nominal ambient temperatures of 0° F to 104° F (-20° C to 40° C). Consult JLG to optimize operation outside of this temperature range.

### Machine Inspection

- Do not operate this machine until the inspections and functional checks have been performed as specified in Section 2 of this manual.
- Do not operate this machine until it has been serviced and maintained according to the maintenance and inspection requirements as specified in the machine's Service and Maintenance Manual.
- Ensure all safety devices are operating properly. Modification of these devices is a safety violation.



**MODIFICATION OR ALTERATION OF A MEWP SHALL BE MADE ONLY WITH PRIOR WRITTEN PERMISSION FROM THE MANUFACTURER.**

- Do not operate any machine on which the safety or instruction placards or decals are missing or illegible.
- Check the machine for modifications to original components. Ensure that any modifications have been approved by JLG.
- Avoid accumulation of debris on platform floor. Keep mud, oil, grease, and other slippery substances from footwear and platform floor.

## **1.3 OPERATION**

### **General**

- Machine operation requires your full attention. Bring the machine to a full stop before using any device, i.e. cell phones, two-way radios, etc. that will distract your attention from safely operating the machine.
- Do not use the machine for any purpose other than positioning personnel, their tools, and equipment.
- Before operation, the user must be familiar with the machine capabilities and operating characteristics of all functions.
- Never operate a malfunctioning machine. If a malfunction occurs, shut down the machine. Remove the unit from service and notify the proper authorities.
- Do not remove, modify, or disable any safety devices.
- Never slam a control switch or lever through neutral to an opposite direction. Always return switch to neutral and stop before moving the switch to the next function. Operate controls with slow and even pressure.
- Do not allow personnel to tamper with or operate the machine from the ground with personnel in the platform, except in an emergency.
- Do not carry materials directly on platform railing unless approved by JLG.
- When two or more persons are in the platform, the operator shall be responsible for all machine operations.
- Always ensure that power tools are properly stowed and never left hanging by their cord from the platform work area.
- Do not assist a stuck or disabled machine by pushing or pulling except by pulling at the chassis tie-down lugs.
- Fully lower platform and shut off all power before leaving machine.
- Remove all rings, watches, and jewelry when operating machine. Do not wear loose fitting clothing or long hair unrestrained which may become caught or entangled in equipment.
- Persons under the influence of drugs or alcohol or who are subject to seizures, dizziness or loss of physical control must not operate this machine.
- Hydraulic cylinders are subject to thermal expansion and contraction. This may result in changes to the platform position while the machine is stationary. Factors affecting thermal movement can include the length of time the machine will remain stationary, hydraulic oil temperature, ambient air temperature and platform position.

## SECTION 1 - SAFETY PRECAUTIONS

---

### Trip and Fall Hazards

- Prior to operation, ensure all gates and rails are fastened and secured in their proper position.

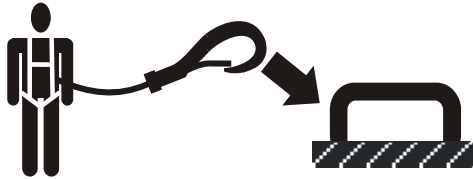

- JLG Industries, Inc. recommends that all persons in the platform wear a full body harness with a lanyard attached to an authorized lanyard anchorage point while operating this machine. For further information regarding fall protection requirements on JLG products, contact JLG Industries, Inc.
- Identify the designated lanyard anchorage point(s) at the platform and securely attach the lanyard. Attach only one (1) lanyard per lanyard anchorage point.
- Enter and exit only through gate area. Use extreme caution when entering or leaving platform. Ensure that the platform assembly is fully lowered. Face the platform when entering or leaving the platform. Always maintain “three point contact” with the machine, using two hands and one foot or two feet and one hand at all times during entry and exit.

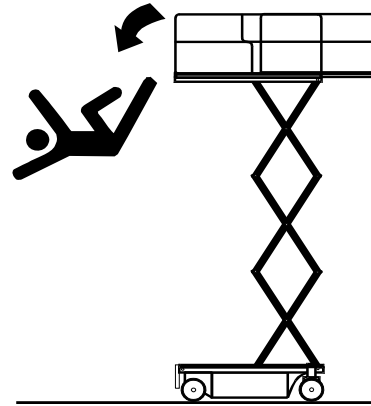

- Keep both feet firmly positioned on the platform floor at all times. Never position ladders, boxes, steps, planks, or similar items on unit to provide additional reach for any purpose.
- Never use the scissor arm assembly to gain access to or leave the platform.
- Keep oil, mud, and slippery substances cleaned from footwear and the platform floor.

## Electrocution Hazards

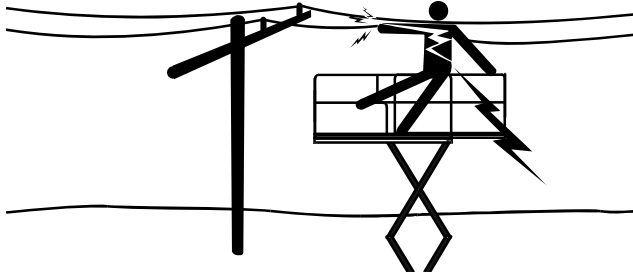

- This machine is not insulated and does not provide protection from contact or proximity to electrical current.
- Maintain distance from electrical lines, apparatus, or any energized (exposed or insulated) parts according to the Minimum Approach Distance (MAD) as shown in Table 1-1.
- Allow for machine movement and electrical line swaying.
- Maintain a clearance of at least 10 ft (3 m) between any part of the machine and its occupants, their tools, and their equipment from any electrical line or apparatus carrying up to 50,000 volts. One foot additional clearance is required for every additional 30,000 volts or less.

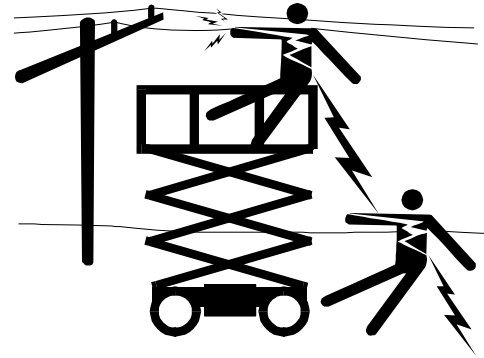

- The minimum approach distance may be reduced if insulating barriers are installed to prevent contact, and the barriers are rated for the voltage of the line being guarded. These barriers shall not be part of (or attached to) the machine. The minimum approach distance shall be reduced to a distance within the designed working dimensions of the insulating barrier. This determination shall be made by a qualified person in accordance with the employer, local, or governmental requirements for work practices near energized equipment.

**⚠ DANGER**

**DO NOT MANEUVER MACHINE OR PERSONNEL INSIDE PROHIBITED ZONE (MAD). ASSUME ALL ELECTRICAL PARTS AND WIRING ARE ENERGIZED UNLESS KNOWN OTHERWISE.**

## SECTION 1 - SAFETY PRECAUTIONS

**Table 1-1. Minimum Approach Distances (M.A.D.)**

VOLTAGE RANGE (Phase to Phase)	MINIMUM APPROACH DISTANCE in Feet (Meters)
0 to 50 KV	10 (3)
Over 50KV to 200 KV	15 (5)
Over 200 KV to 350 KV	20 (6)
Over 350 KV to 500 KV	25 (8)
Over 500 KV to 750 KV	35 (11)
Over 750 KV to 1000 KV	45 (14)
<b>NOTE:</b> <i>This requirement shall apply except where employer, local or governmental regulations are more stringent.</i>	

### Tipping Hazards

- Ensure that the ground conditions are adequate to support the maximum tire load indicated on the tire load decals located on the chassis adjacent to each wheel. Do not travel on unsupported surfaces.
- The user must be familiar with the operating surface before driving. Do not exceed the allowable sideslope and grade while driving.
- Do not elevate platform or drive with platform elevated while on or near a sloping, uneven, or soft surface. Ensure machine is positioned on a smooth, firm surface within the limits of the maximum operating slope before elevating platform or driving with the platform in the elevated position.

- Before driving on floors, bridges, trucks, and other surfaces, check allowable capacity of the surfaces.
- Never exceed the maximum platform capacity as specified on the platform. Keep all loads within the confines of the platform, unless authorized by JLG.
- Keep the chassis of the machine a minimum of 2 ft (0.6 m) from holes, bumps, drop-offs, obstructions, debris, concealed holes, and other potential hazards at the ground level.
- Do not operate the machine when wind conditions exceed specifications shown in Section 6.3 or as shown on the capacity placard on the platform billboard. Factors affecting wind speed are; platform elevation, surrounding structures, local weather events, and approaching storms.
- Wind speed can be significantly greater at height than at ground level.
- Wind speed can change rapidly. Always consider approaching weather events, the time required to lower the platform, and methods to monitor current and potential wind conditions.
- Do not cover or increase surface area of the platform or the load. Do not carry large surface area items in the platform when operating outdoors. The addition of such items increases the exposed wind area of the machine. Increased areas exposed to wind will decrease stability.
- Do not increase the platform size with unauthorized modifications, deck extensions, or attachments.



**⚠ WARNING**

**DO NOT OPERATE THE MACHINE WHEN WIND CONDITIONS EXCEED SPECIFICATIONS SHOWN IN SECTION 6.3 OR AS SHOWN ON THE CAPACITY PLACARD ON THE PLATFORM BILLBOARD.**

**Table 1-2. Beaufort Scale (For Reference Only)**

BEAUFORT NUMBER	WIND SPEED		DESCRIPTION	LAND CONDITIONS
	mph	m/s		
0	0	0-0.2	Calm	Calm. Smoke rises vertically.
1	1-3	0.3-1.5	Light air	Wind motion visible in smoke.
2	4-7	1.6-3.3	Light breeze	Wind felt on exposed skin. Leaves rustle.
3	8-12	3.4-5.4	Gentle breeze	Leaves and smaller twigs in constant motion.
4	13-18	5.5-7.9	Moderate breeze	Dust and loose paper raised. Small branches begin to move.
5	19-24	8.0-10.7	Fresh breeze	Smaller trees sway.
6	25-31	10.8-13.8	Strong breeze	Large branches in motion. Flags waving near horizontal. Umbrella use becomes difficult.
7	32-38	13.9-17.1	Near Gale/Moderate Gale	Whole trees in motion. Effort needed to walk against the wind.
8	39-46	17.2-20.7	Fresh Gale	Twigs broken from trees. Cars veer on road.
9	47-54	20.8-24.4	Strong Gale	Light structure damage.

## SECTION 1 - SAFETY PRECAUTIONS

---

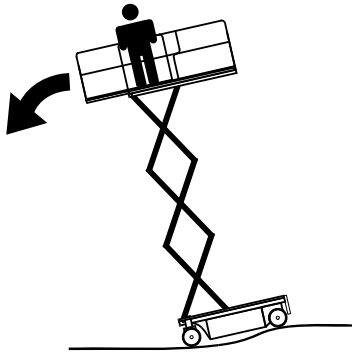
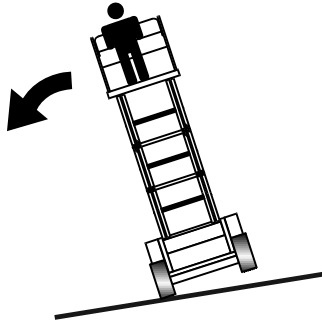

- Never attempt to use the machine as a crane. Do not tie-off machine to any adjacent structure. Never attach wire, cable, or any similar items to platform.
- If the scissor arm assembly or platform is caught so that one or more wheels are off the ground, all persons must be removed before attempting to free the machine. Use cranes, forklift trucks, or other appropriate equipment to stabilize machine.

### Crushing and Collision Hazards

- Approved head gear must be worn by all operating and ground personnel.
- Keep hands and limbs out of the scissor arm assembly during operation and when elevated without safety prop engaged.
- Watch for obstructions around machine and overhead when driving. Check clearances above, on sides, and bottom of platform when lifting or lowering platform.
- During operation, keep all body parts inside platform railing.

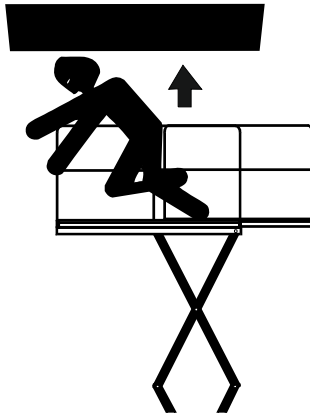

- Always post a lookout when driving in areas where vision is obstructed.
- Keep non-operating personnel at least 6 ft (1.8 m) away from machine during all operations.
- Under all travel conditions, the operator must limit travel speed according to conditions of ground surface, congestion, visibility, slope, location of personnel, and other factors.
- Be aware of stopping distances in all drive speeds. When driving in high speed, reduce drive speed before stopping. Travel grades in low speed only.
- Do not use high speed drive in restricted or close quarters or when driving in reverse.
- Exercise extreme caution at all times to prevent obstacles from striking or interfering with operating controls and persons in the platform.
- Ensure that operators of other overhead and floor level machines are aware of the MEWP's presence. Disconnect power to overhead cranes. Barricade floor area if necessary.
- Do not operate over ground personnel. Warn personnel not to work, stand, or walk under a raised platform. Position barricades on floor as necessary.

### **⚠ WARNING**

**IF DRIVING MACHINE WITH THE PLATFORM CONTROL STATION FROM GROUND, DO NOT HANG THE CONTROL BOX ON ANY PART OF THE MACHINE WHILE DRIVING. HOLD THE CONTROL BOX AND KEEP AT LEAST 3 FT (1 M) DISTANCE FROM MACHINE.**

## **SECTION 1 - SAFETY PRECAUTIONS**

---

### **1.4 TOWING, LIFTING, AND HAULING**

- Never allow personnel in platform while towing, lifting, or hauling.
- This machine should not be towed, except in the event of emergency, malfunction, power failure, or loading/unloading. Refer to emergency towing procedures.
- Ensure platform is fully retracted and completely empty of tools prior to towing, lifting or hauling.
- When lifting machine with a forklift, position forks only at designated areas of the machine. Lift with a forklift of adequate capacity.
- Refer to Section 3 for lifting information.

### **1.5 MAINTENANCE**

This sub-section contains general safety precautions which must be observed during maintenance of this machine. Additional precautions to be observed during machine maintenance are inserted at the appropriate points in this manual and in the Service and Maintenance Manual. It is of utmost importance that maintenance personnel pay strict attention to these precautions to avoid possible injury to personnel or damage to the machine or property. A maintenance program must be established by a qualified person and must be followed to ensure that the machine is safe.

#### **Maintenance Hazards**

- Shut off power to all controls and ensure that all moving parts are secured from inadvertent motion prior to performing any adjustments or repairs.
- Never work under an elevated platform until it has been fully lowered to the full down position, if possible, or otherwise supported and restrained from movement with appropriate safety props, blocking, or overhead supports.
- DO NOT attempt to repair or tighten any hydraulic hoses or fittings while the machine is powered on or when the hydraulic system is under pressure.

- Always relieve hydraulic pressure from all hydraulic circuits before loosening or removing hydraulic components.
- DO NOT use your hand to check for leaks. Use a piece of cardboard or paper to search for leaks. Wear gloves to help protect hands from spraying fluid.
- Use only replacement parts or components that are approved by JLG. To be considered approved, replacement parts or components must be identical or equivalent to original parts or components.
- Never attempt to move heavy parts without the aid of a mechanical device. Do not allow heavy objects to rest in an unstable position. Ensure adequate support is provided when raising components of the machine.
- Use only approved non-flammable cleaning solvents.
- Do not replace items critical to stability, such as batteries or tires, with items of different weight or specification. Do not modify the MEWP in any way to affect stability.
- Reference the Service and Maintenance Manual for the weights of critical stability items.



### Battery Hazards

- Always disconnect batteries when servicing electrical components or when performing welding on the machine.
- Do not allow smoking, open flame, or sparks near battery during charging or servicing.
- Do not contact tools or other metal objects across the battery terminals.
- Always wear hand, eye, and face protection when servicing batteries. Ensure that battery acid does not come in contact with skin or clothing.

### CAUTION

**BATTERY FLUID IS HIGHLY CORROSIVE. AVOID CONTACT WITH SKIN AND CLOTHING AT ALL TIMES. IMMEDIATELY RINSE ANY CONTACTED AREA WITH CLEAN WATER AND SEEK MEDICAL ATTENTION.**

- Charge batteries only in a well ventilated area.
- Avoid overfilling the battery fluid level. Add distilled water to batteries only after the batteries are fully charged.

### WARNING

**MODIFICATION OR ALTERATION OF A MEWP SHALL BE MADE ONLY WITH PRIOR WRITTEN PERMISSION FROM THE MANUFACTURER.**



## **SECTION 2. USER RESPONSIBILITIES, MACHINE PREPARATION, AND INSPECTION**

### **2.1 PERSONNEL TRAINING**

The Mobile Elevating Work Platform (MEWP) is a personnel handling device, so it is necessary that it be operated and maintained only by trained personnel.

#### **Operator Training**

Operator training must cover:

1. Reading and understanding the Operation and Safety Manual.
2. Thorough understanding of the intended purpose and function of the MEWP controls, including platform, ground, and emergency descent controls.
3. Control labels, instructions, and warnings on the machine.
4. Applicable regulations, standards, and safety rules.
5. Use of approved fall protection equipment.
6. Enough knowledge of the mechanical operation of the machine to recognize a malfunction or potential malfunction.
7. The safest means to operate the machine where overhead obstructions, other moving equipment, and obstacles, depressions, holes, and drop-offs exist.
8. Means to avoid the hazards of unprotected electrical conductors.

9. Selection of the appropriate MEWPs and available options for the work to be performed considering specific job requirements, with involvement from the MEWP owner, user, and/or supervisor.
10. The responsibility of the operator to ensure all platform occupants have a basic level of knowledge to work safely on the MEWP, and to inform them of applicable regulations, standards, and safety rules.
11. The requirement for familiarization in addition to training.

#### **Training Supervision**

Training must be delivered by a qualified person in an open area free of hazards until the trainee has demonstrated the ability to safely control and operate the machine.

#### **Operator**

The operator must be instructed that they have the responsibility and authority to shut down the machine in case of a malfunction or other unsafe condition of either the machine or the job site.

### Machine Familiarization

**NOTE:** *Responsibilities for familiarization may vary by region.*

Only properly trained personnel who have received unit-specific familiarization shall operate a MEWP. The user shall determine if personnel are qualified to operate the MEWP prior to operation. The user shall ensure that after familiarization, the operator operates the MEWP for a sufficient period of time to achieve proficiency. When authorized by the user, self-familiarization can be achieved, if authorized, by a properly trained operator reading, understanding and following the manufacturer's operator's manual.

Prior to users authorization of an operator to use a specific model of MEWP, the user shall ensure the operator is familiarized on the following:

1. Location of the manual storage compartment and the requirement to ensure the required manual(s) are present on the MEWP;
2. Purpose and function of the machine controls and indicators at the platform and ground control stations;
3. Purpose, location, and function of the emergency controls;
4. Operating characteristics and limitations;
5. Features and devices;
6. Accessories and optional equipment.

### 2.2 PREPARATION, INSPECTION, AND MAINTENANCE

The following table covers machine inspections and maintenance required by JLG Industries, Inc. Consult local regulations for further requirements for MEWPs. Frequency of inspections and maintenance must be increased as necessary when machine is used in a harsh or hostile environment, if machine is used with increased frequency, or if machine is used in a severe manner.



## SECTION 2 - USER RESPONSIBILITIES, MACHINE PREPARATION, AND INSPECTION

### Inspection and Maintenance Table

TYPE	FREQUENCY	PRIMARY RESPONSIBILITY	SERVICE QUALIFICATION	REFERENCE
Pre-Start Inspection	Before using each day, or whenever there's an operator change.	User or Operator	User or Operator	Operation and Safety Manual
Pre-Delivery Inspection <i>(see Note below)</i>	Before each sale, lease, or rental delivery.	Owner, Dealer, or User	Qualified JLG Mechanic	Service and Maintenance Manual and applicable JLG inspection form
Frequent Inspection	In service for 3 months or 150 hours, whichever comes first; or out of service for a period of more than 3 months; or purchased used.	Owner, Dealer, or User	Qualified JLG Mechanic	Service and Maintenance Manual and applicable JLG inspection form
Annual Machine Inspection <i>(see Note below)</i>	Annually, no later than 13 months from the date of prior inspection.	Owner, Dealer, or User	Factory Trained Service Technician (Recommended)	Service and Maintenance Manual and applicable JLG inspection form
Preventative Maintenance	At intervals as specified in the Service and Maintenance Manual.	Owner, Dealer, or User	Qualified JLG Mechanic	Service and Maintenance Manual

**NOTE:** *Inspection forms are available from JLG. Use the Service and Maintenance Manual to perform inspections.*

### NOTICE

**JLG INDUSTRIES, INC. RECOGNIZES A FACTORY-TRAINED SERVICE TECHNICIAN AS A PERSON WHO HAS SUCCESSFULLY COMPLETED THE JLG SERVICE TRAINING SCHOOL FOR THE SPECIFIC JLG PRODUCT MODEL.**

## SECTION 2 - USER RESPONSIBILITIES, MACHINE PREPARATION, AND INSPECTION

### 2.3 PRE-START INSPECTION

The Pre-Start Inspection should include each of the following:

1. **Cleanliness** – Check all surfaces for leakage (oil or battery fluid) or foreign objects. Report this to the proper maintenance personnel.
2. **Structure** – Inspect the machine structure for dents, damage, weld or parent metal cracks, or other discrepancies. Report this to the proper maintenance personnel.

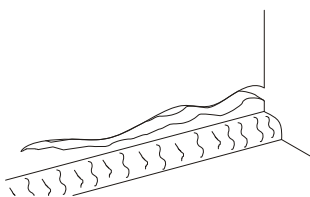

Parent Metal Crack



Weld Crack

3. **Decals and Placards** – Check all for cleanliness and legibility; clean or replace as necessary. Ensure none of the decals and placards are missing (refer to Section 6.8).
4. **Operation and Safety Manuals** – Ensure a copy of the Operation and Safety Manual, AEM Safety Manual (ANSI markets only), and ANSI Manual of Responsibilities (ANSI markets only) is enclosed in the weather-resistant storage container.

5. **Walk-Around Inspection** – Perform as instructed in Section 2.4.
6. **Battery** – Charge as required.
7. **Hydraulic Oil Level** – Check the hydraulic oil level in the pump reservoir and add as required (refer to Section 6.6).
8. **Accessories/Attachments** – Refer to the Accessories section in this manual or accessory installed upon the machine for specific inspection, operation, and maintenance instructions.
9. **Function Check** – Once the Walk-Around Inspection is complete, perform a functional check of all systems in an area free of overhead and ground level obstructions. Refer to Section 3 for more specific instructions on the operation of each function.
10. **Platform Gate** – Keep gate and surrounding area clean and unobstructed. Ensure the gate closes properly and is not bent or damaged. Keep gate closed at all times except when entering/exiting the platform and loading/unloading materials.
11. **Lanyard Attach Points** – JLG Industries, Inc. recommends personnel in the platform wear a full body harness with a lanyard attached to an authorized lanyard attach point.

#### **⚠ WARNING**

**IF THE MACHINE DOES NOT OPERATE PROPERLY, TURN OFF THE MACHINE IMMEDIATELY! REPORT THE PROBLEM TO THE PROPER MAINTENANCE PERSONNEL. DO NOT OPERATE THE MACHINE UNTIL IT IS DECLARED SAFE FOR OPERATION.**

**SECTION 2 - USER RESPONSIBILITIES, MACHINE PREPARATION, AND INSPECTION**

---

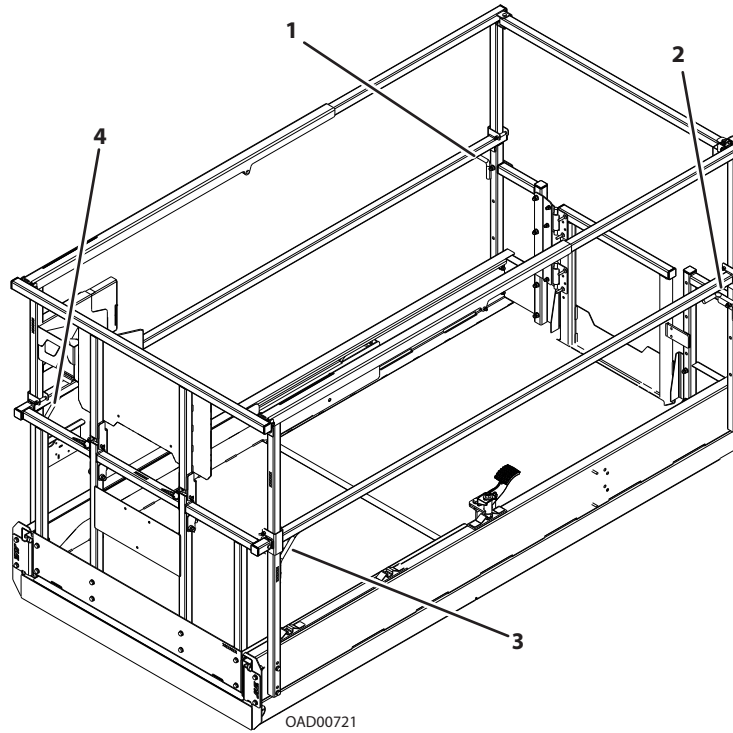

**Lanyard Attach Points**

## SECTION 2 - USER RESPONSIBILITIES, MACHINE PREPARATION, AND INSPECTION

### 2.4 WALK-AROUND INSPECTION

Begin the Walk-Around Inspection at item 1 as noted on the Inspection Diagram. Continue checking each item in sequence for the conditions listed in the following checklist.

#### **WARNING**

**TO AVOID POSSIBLE INJURY, BE SURE MACHINE POWER IS "OFF". DO NOT OPERATE UNTIL ALL MALFUNCTIONS HAVE BEEN CORRECTED.**

#### **NOTICE**

**DO NOT OVERLOOK VISUAL INSPECTION OF CHASSIS UNDERSIDE. CHECKING THIS AREA MAY RESULT IN DISCOVERY OF CONDITIONS WHICH COULD CAUSE EXTENSIVE MACHINE DAMAGE.**

**INSPECTION NOTE:** *On all components, make sure there are no loose or missing parts, that they are securely fastened, and that no visible damage, leaks, or excessive wear exists in addition to any other criteria mentioned.*

- 1. Frame/Chassis/Ladder** – Ensure pothole protection (PHP) components on frame are in place, undamaged, not bent or worn. Side compartment doors open and close properly. Refer to Inspection Note.
- 2. Rear Wheels, Tires, and Hydraulic Brakes** – Wheel nut properly secured (refer to Section 6.7). Inspect wheels, steer linkage, and steer cylinder for damage and corrosion. Check hydraulic brake hoses for damage or leakage. Refer to Inspection Note.
- 3. Ground Control Console** – Placard secure and legible, control switches return to neutral position when activated and released, emergency stop switch functions properly. Control markings legible.
- 4. Hydraulic Pump/Motor, Control Valve Installation** – No unsupported wires or hoses; no damaged or broken wires. Refer to Inspection Note.
- 5. Front Wheels and Tires** – Wheel nut properly secured (refer to Section 6.7). Inspect wheels, steer linkage, and steer cylinder for damage and corrosion. Refer to Inspection Note.
- 6. Battery Compartment** – Refer to Inspection Note.
- 7. Scissor Arm Stack Assembly, Pivot Pins, Slide Wear Pads, Lift Cylinder** – Refer to Inspection Note.
- 8. Platform/Rail/Gate Assembly** – Deck extension slides in and out and locks in place properly. All fold-down rail pins (if equipped) in place and secure. Refer to Inspection Note.
- 9. Magnetic Gate Latch** – Gate swings freely and latches securely.
- 10. Platform Control Console** – Ensure the control console is firmly secured in the proper location. Placards secure and legible, control lever and switches return to neutral when activated and released, and emergency stop switch function properly, required manual(s) in storage box.
- 11. Safety Prop** – Refer to Inspection Note.
- 12. Platform Manual Descent** – Refer to Inspection Note.
- 13. Static Strap** – Refer to Inspection Note.

Inspection Diagram

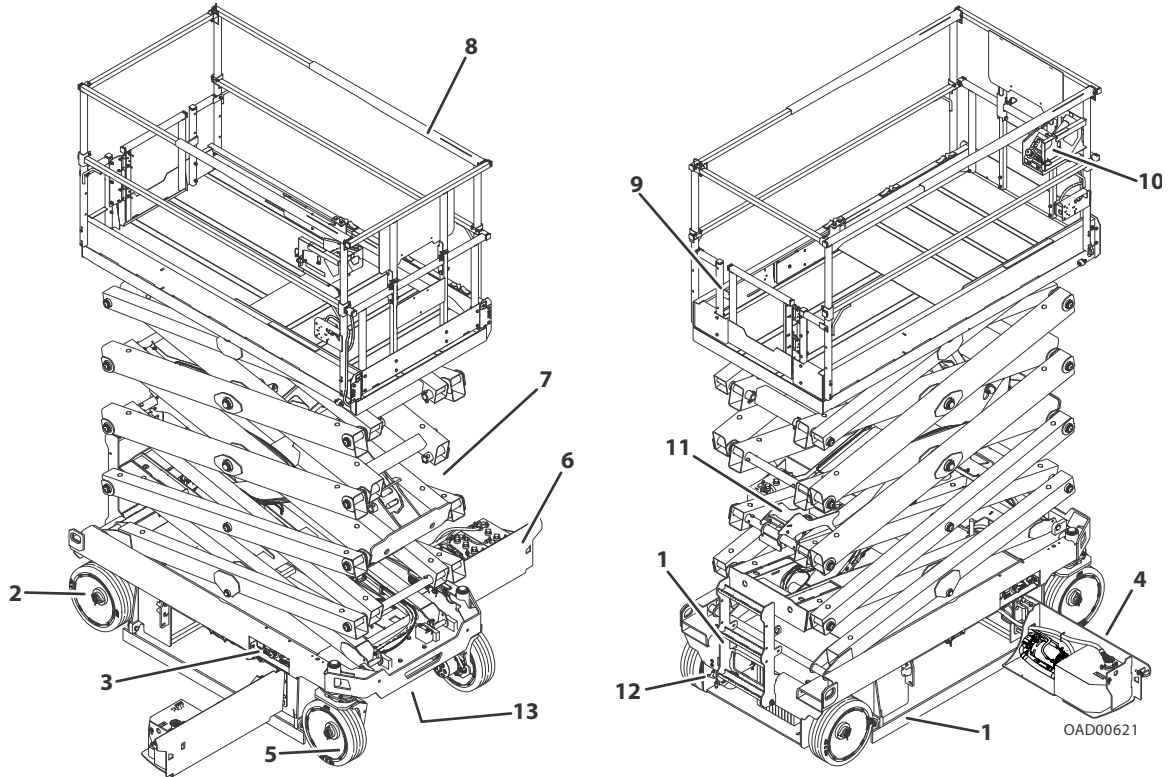

OAD00621

## SECTION 2 - USER RESPONSIBILITIES, MACHINE PREPARATION, AND INSPECTION

### 2.5 FUNCTION CHECK

Perform the Function Check as follows:

1. At the **Ground Control Panel** with no load in the platform:
  - a. Ensure the key selector switch and platform lift switch operate properly.
  - b. Ensure all machine functions are disabled when the Emergency Stop Button is depressed.
  - c. With the platform raised a few feet (1 m), ensure the manual descent control (T-handle located at rear of machine next to the battery charger) lowers the platform (refer to Section 3.8).
  - d. Verify the Pothole Protection bars are fully lowered when the platform is raised.

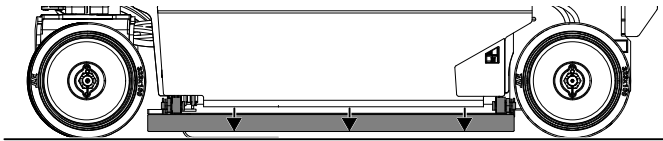

**Platform Elevated - Pothole Bars Fully Lowered**

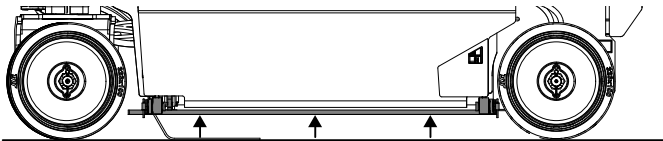

**Platform Fully Lowered - Pothole Bars Raised**

2. From the **Platform Control Console**:
  - a. Ensure the control console is firmly secured in the proper location.
  - b. Ensure all guards protecting switches are in place.
  - c. Operate all switch functions, drive/lift mode select switch, and horn button.
  - d. Operate all platform joystick functions to ensure proper operation of drive, lift, steer, and enable trigger switch.
  - e. Ensure all machine functions stop when function control is released or when joystick trigger is released.
  - f. Ensure all machine functions are disabled when the platform Emergency Stop Button is depressed.

## SECTION 2 - USER RESPONSIBILITIES, MACHINE PREPARATION, AND INSPECTION

- g.** With the platform elevated on a smooth, firm, level surface with no overhead obstructions, drive the machine to check if the high drive cutback speed limit is engaged at the height indicated in Table 2-1. Ensure drive speed reduces from high speed to a slower speed.

**Table 2-1. High Drive Cutout Height**

MODEL	HIGH DRIVE SPEED CUTBACK HEIGHT	DRIVE SPEED REDUCTION
R2632	55 in (1.40 m)	2.0 mph (3.2 kph) to 0.5 mph (0.8 kph)
R3246	62 in (1.57 m)	2.2 mph (3.5 kph) to 0.5 mph (0.8 kph)

**3. With the platform in the stowed position:**

- a.** Drive the machine on a grade, not to exceed the rated gradeability, and stop to ensure the drive motor brakes hold.
- b.** Check the tilt indicator light to verify proper operation. The light should be illuminated if tilted beyond allowed settings shown in Table 2-2.

**NOTE:** When the tilt indicator warning is activated, drive and lift up functions are disabled and the platform must be fully lowered (stowed) to drive.

**Table 2-2. Tilt Activation Setting**

MODEL	TILT SETTING (Front to Back)	TILT SETTING (Side to Side)	Maximum Platform Elevation
R2632	3.5°	1.50° - indoor	20.5 ft - 25.5 ft (6.25 m - 7.77 m)
		1.50° - outdoor	18 ft - 21 ft (5.5 m - 6.4 m)
		2.25° - indoor	16.5 ft - 20.5 ft (5 m - 6.25 m)
		2.50° - outdoor	14 ft - 18 ft (4.3 m - 5.5 m)
		3.50° - indoor	55 in - 16.5 ft (1.4 m - 5 m)
		4.50° - outdoor	55 in - 14 ft (1.4 m - 4.3 m)

**NOTE:** Machine R2632 does not have outdoor functionality in the AUS market.

MODEL	TILT SETTING (Front to Back)	TILT SETTING (Side to Side)	Maximum Platform Elevation
R3246	3.5°	2.50° - indoor	27 ft - 32 ft (8.23 - 9.75 m)
		1.50° - outdoor	
		2.75° - indoor	22 ft - 27 ft (6.7 - 8.23 m)
		2.25° - outdoor	
		3.75° - indoor	65 in - 22 ft (1.65 - 6.7 m)
		3.50° - outdoor	





## **SECTION 3. MACHINE CONTROLS, INDICATORS, AND OPERATION**

### **3.1 GENERAL**

#### **NOTICE**

**THE MANUFACTURER HAS NO DIRECT CONTROL OVER MACHINE APPLICATION AND OPERATION. THE USER AND OPERATOR ARE RESPONSIBLE FOR CONFORMING WITH GOOD SAFETY PRACTICES.**

This section provides the necessary information needed to understand the machine's controls and their functions.

#### **⚠ WARNING**

**DO NOT RAISE PLATFORM UNLESS THE MACHINE IS ON A SMOOTH, FIRM SURFACE, WITHIN THE LIMITS OF THE MAXIMUM OPERATING SLOPE, FREE OF OBSTRUCTIONS AND HOLES.**

**TO AVOID SERIOUS INJURY, DO NOT OPERATE MACHINE IF ANY CONTROL LEVERS OR TOGGLE SWITCHES CONTROLLING PLATFORM MOVEMENT DO NOT RETURN TO THE OFF OR NEUTRAL POSITION WHEN RELEASED.**

**IF THE PLATFORM DOES NOT STOP WHEN A CONTROL SWITCH OR LEVER IS RELEASED, USE THE EMERGENCY STOP SWITCH TO STOP THE MACHINE.**

### **3.2 DESCRIPTION**

This machine is a Mobile Elevating Work Platform (MEWP) used to position personnel, along with their necessary tools and materials at work locations.

This MEWP has a primary operator control station in the platform. From this control station, the operator can drive and steer the machine in both forward and reverse directions, and raise and lower the platform.

The machine can be driven on a smooth, firm surface within the limits of the maximum operating slope from an elevated platform position. Refer to the subsection Steering and Traveling of this manual for specific requirements.

The machine also has a ground control station that can override the platform control station. Ground controls operate lift up and down functions only. Except for performing inspections and function checks, ground controls are to be used only in an emergency to lower the platform to the ground should the operator in the platform be unable to do so.

### 3.3 OPERATING CHARACTERISTICS AND LIMITATIONS

#### Placards

Important points to remember during operation are provided at the control stations by DANGER, WARNING, CAUTION, NOTICE, and INSTRUCTION placards. This information is placed at various locations for the express purpose of alerting personnel of potential hazards constituted by the operating characteristics and limitations of the machine. Refer to the FOREWORD for definitions of placard safety signal words.

#### Capacities

Raising platform above horizontal with or without any load in platform is based on the following criteria:

1. Machine is positioned on a smooth, firm surface within the limits of the maximum operating slope.
2. Load is within manufacturer's rated capacity.
3. All machine systems are functioning properly.

#### Stability

This machine, as originally manufactured by JLG and operated within its rated capacity on a smooth, firm surface, within the limits of the maximum operating slope, provides a stable aerial platform for all platform positions.

### 3.4 PLATFORM LOADING

The platform maximum rated load capacity is shown on a placard located on the platform billboard and is based upon the machine positioned on a smooth, firm surface, within the limits of the maximum operating slope. Refer to Section 6.3 for the maximum platform capacity.

The platform is entered through an entry gate at the rear of the platform. Keep entry gate closed at all times except when entering/exiting the platform and loading/unloading materials.

**NOTE:** *It is important to remember that the load should be evenly distributed on the platform. The load should be placed near the center of the platform when possible.*

### 3.5 BATTERY CHARGING

The battery charger AC input plug is located inside the frame at the left rear of the machine next to the battery charger. Refer to Section 6.4 for battery charger specifications.

1. Connect the charger AC input plug to a grounded outlet using a 3 wire heavy duty extension cord.

**NOTE:** Park the machine in a well-ventilated area before charging.



**ONLY PLUG THE CHARGER INTO A PROPERLY INSTALLED AND GROUNDED OUTLET. DO NOT USE GROUND ADAPTERS OR MODIFY PLUG IN ANY WAY. DO NOT TOUCH NON-INSULATED PORTION OF OUTPUT CONNECTOR OR NON-INSULATED BATTERY TERMINAL.**

**DO NOT OPERATE CHARGER IF THE AC SUPPLY CORD IS DAMAGED, OR IF THE CHARGER HAS RECEIVED A SHARP BLOW, BEEN DROPPED, OR OTHERWISE DAMAGED IN ANY WAY.**

**ALWAYS DISCONNECT THE CHARGER AC SUPPLY BEFORE MAKING OR BREAKING THE (POSITIVE/NEGATIVE) CONNECTIONS TO THE BATTERY.**

**DO NOT OPEN OR DISASSEMBLE CHARGER.**

2. After connecting the charger to an AC outlet at the start of the charging cycle, verify normal operation of the LED indicators on the charger (refer to Section 6.6).

**NOTE:** Current battery charge state can also be seen on the platform control station panel LEDs or the MDI indicator (if equipped) on the ground control station when machine is powered up.

3. The batteries are fully charged when all three GREEN LED indicators on the platform control station or MDI battery charger status panel are illuminated.

**NOTE:** If the charger is left plugged in, it will automatically restart a complete charge cycle if the batteries voltage drops below a minimum voltage or if 30 days has elapsed.

**3.6 MACHINE CONTROL LOCATIONS**

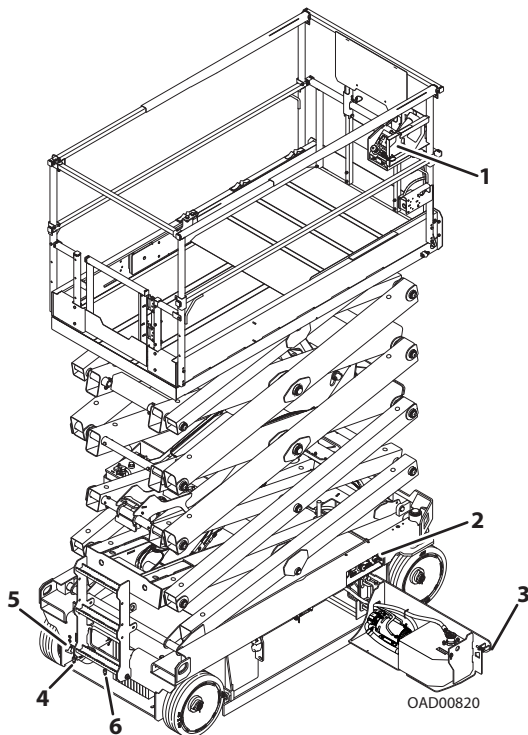

- 1. Platform Control Station
- 2. Ground Control Station
- 3. Side Compartment Door Latch (Both Sides)
- 4. A/C Plug (Battery Charger Input)
- 5. Platform Manual Descent
- 6. A/C Plug (Platform A/C Receptacle Outlet Box)

3.7 GROUND CONTROL CONSOLE

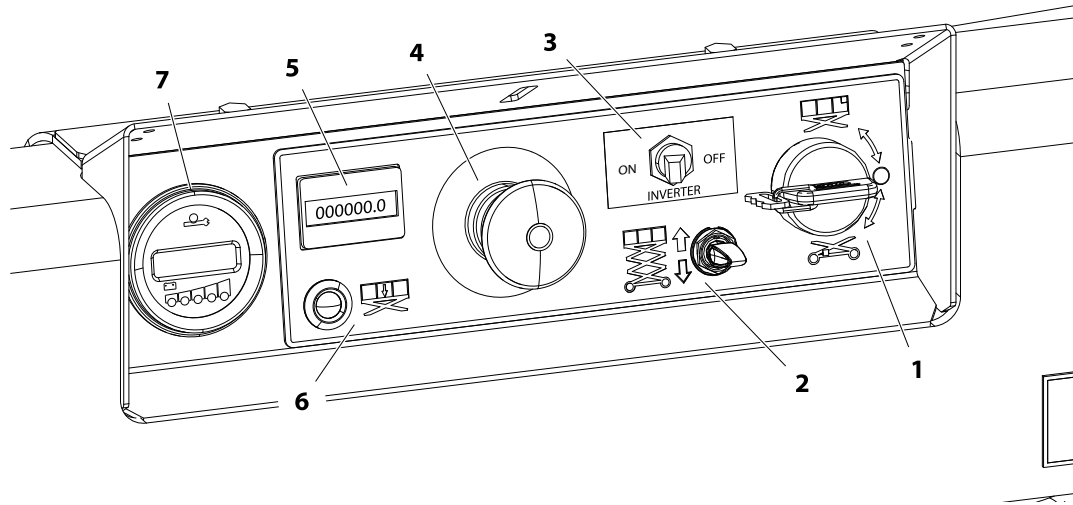

- 1. Ground/Platform/OFF Key Selector Switch
- 2. Platform Lift/Lower Switch
- 3. Inverter ON/OFF Switch (If Equipped)
- 4. Ground Emergency Stop Button

- 5. Hourmeter
- 6. Overload Indicator (LSS)
- 7. MDI Indicator (If Equipped)

### **⚠ WARNING**

**DO NOT OPERATE MACHINE FROM THE GROUND CONTROL CONSOLE WITH PERSONNEL IN THE PLATFORM EXCEPT IN AN EMERGENCY.**

### **Ground/Platform/OFF Key Selector Switch**

The key selector switch on the Ground Control Station directs electrical power to the desired control station. When the switch is turned to the ground position (1), power is supplied to the controls at the ground control console. When the switch is turned to the platform position (2), power is supplied to the controls at the platform control console. The switch should be set to the OFF position (3) when not using machine or parking the machine overnight.

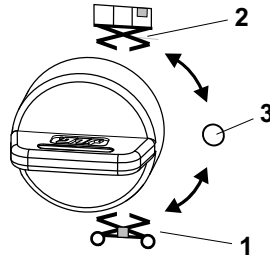

### **Platform Lift/Lower Switch**

A three-position momentary contact switch controls raising and lowering of the platform from the ground control console.

**NOTE:** *There will be a brief delay between switch activation and movement of the platform.*

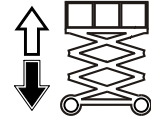

### **When operating platform from the ground controls -**

Toggle the lift/lower switch to up position and hold to raise platform, or down position and hold to lower an elevated platform. Release to center position to stop all movement.

### **Inverter ON/OFF Switch (If Equipped)**

When switched on, the inverter converts DC voltage stored in the on-board batteries to AC voltage for use at the AC receptacle outlet mounted in the platform.

### Ground Emergency Stop Switch

A red two-position emergency stop switch when positioned to ON with the key selector switch positioned to ground furnishes operating power to the ground control station key switch. In addition, the switch can be used to turn off power to the function controls in the event of an emergency. Turn on power by pulling out the switch. Turn off power by depressing switch.



### Hourmeter

The Hourmeter indicates the number of hours the machine has been operated.

000000  
HOURS

### Overload Indicator (LSS)

The Overload Indicator indicates when the platform has been overloaded. An audible alarm will also signal when the platform is overloaded.

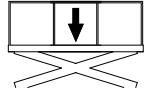

**NOTE:** *If the Overload Indicator is illuminated, further elevation will be prevented. Reduce the weight in the platform to not exceed the rated workload indicated on the capacity decal, then the controls will work again.*

**NOTE:** *When ambient temperatures are below freezing, the LSS will have a reduction in available capacity. This will trigger the LSS before achieving the maximum allowable capacity.*

## SECTION 3 - MACHINE CONTROLS, INDICATORS, AND OPERATION

### MDI Indicator (If Equipped)

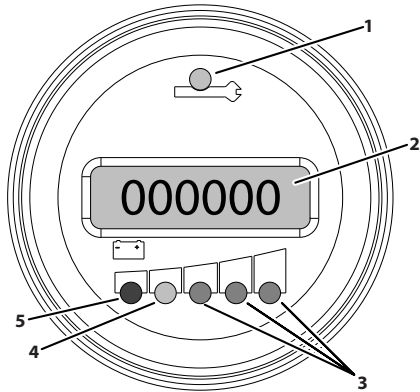

1. System Fault LED Indicator (Red LED)
2. Hourmeter/DTC Code Display
3. 100% Battery Charge Indicator (Green)
4. Battery Charge Low Indicator (Yellow)
5. Battery Re-Charge Indicator (Red)

The Multifunction Digital Indicator (MDI) displays a Battery Discharge Indicator (BDI), a LCD display showing the current hourmeter reading, a system distress LED, and Diagnostic Trouble Codes (DTC) when a functional problem occurs with the machine.

When a problem occurs and a DTC Code is displayed:

- A LED wrench icon (1) illuminates.
- A three to five digit DTC code displays on the DTC LCD display (2) below the wrench icon.

**NOTE:** When more than one DTC exists, each DTC will be displayed on the LCD for 3 seconds before changing to the next DTC. Once the last active DTC is displayed, the display will recycle indefinitely until they are corrected.

Also located on the MDI are Battery Discharge Indicators (BDI) (3, 4, 5). The three green LEDs indicate the level of charge (voltage) remaining in the batteries.

**NOTE:** When the battery voltage is low and will need a charge soon, the yellow LED (4) begin to flash.

BDIs and the hourmeter display under normal operating conditions. When a DTC exists other than 00x, the BDI LEDs and hourmeter are not displayed. Additionally, when the platform is elevated and the machine is driving in creep mode, the turtle icon is displayed.



**3.8 PLATFORM CONTROL STATION**

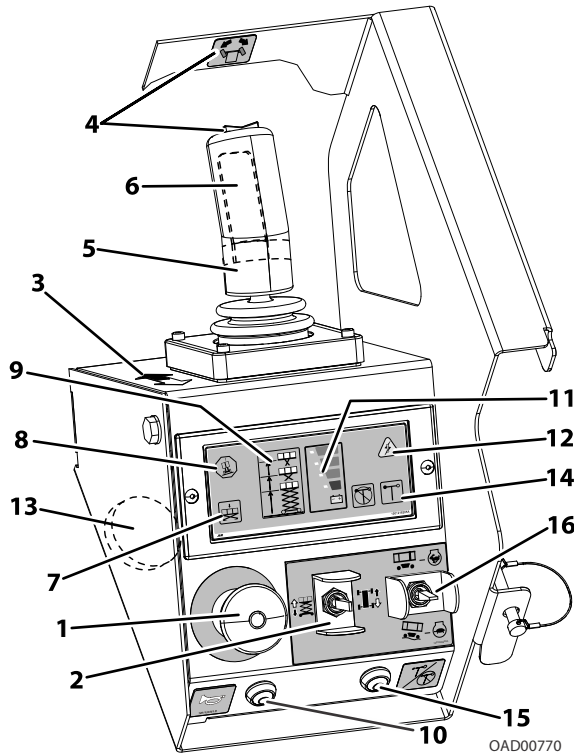

1. Emergency Stop Switch
2. Lift/Drive Selector Switch
3. Forward/Reverse/Lift/Lower Directional Arrow
4. Steer Control Switch and Decal
5. Joystick Controller
6. Trigger Enable Switch
7. Overload Indicator (LSS)
8. Tilt Indicator
9. Variable Tilt - Platform Restricted Height Indicator
10. Horn Button
11. Battery Discharge Indicator
12. System Fault Indicator
13. Alarm
14. Indoor/Outdoor Capacity Indicators
15. Indoor/Outdoor Capacity Selector Switch  
(All Markets Except R2632 in AUS)
16. Drive Speed Selector Switch (R3246 Only)

## SECTION 3 - MACHINE CONTROLS, INDICATORS, AND OPERATION

### Emergency Stop Switch

**NOTE:** Both ground and platform emergency stop switches must be set to ON in order to operate the machine.

When power is directed to the platform from the ground control station, the platform emergency stop switch is turned on by pulling the switch out (on) and is turned off by pushing the switch in (off). The red two-position emergency stop switch functions to provide power to the platform control station and also to turn off power to machine functions in the event of an emergency.

#### **NOTICE**

**ALWAYS POSITION EMERGENCY STOP SWITCH TO "OFF" POSITION (PUSHED IN) WHEN MACHINE IS NOT IN USE.**

### Lift/Drive Selector Switch

**NOTE:** When selecting between the Lift and Drive functions the joystick control must be returned to the neutral position for approximately 1/2 second before the function change is operable.

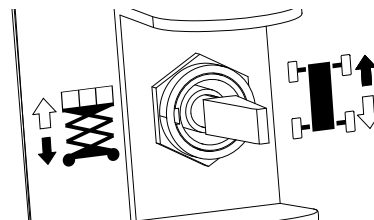

This toggle switch is used to select operation of either the drive or lift function. After selecting a function, the joystick controller must be used to activate that function. Only change the function selected, with the joystick in the neutral position. Otherwise, the function selected will not change until the joystick is returned to the neutral position.

### Forward/Reverse/Lift/Lower Directional Arrow

This decal indicates the proper direction to mount the platform control box, with the black arrow pointing to the front of the machine. The black/white arrow also indicates the direction to move the joystick control per the lift/drive selector switch decal for the lift and the drive select functions.

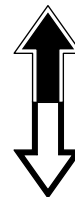

### Drive/Lift/Steer Joystick Control

**Trigger (Enable) Switch** - This trigger switch is located on the front of the joystick controller. It acts as an enable and must be depressed before operating the drive, steer, and lift functions. When released, the function in operation will stop.

The speed on all functions is proportionally controlled by the distance from the neutral (center) position of the joystick controller.

**NOTE:** *Once the trigger switch is pressed, the operator has five seconds to engage a function. After five seconds, the trigger switch must be released and pressed again to operate.*

**NOTE:** *If the machine is also equipped with a footswitch, depress the footswitch in conjunction with the trigger (enable) switch located on the joystick controller. Power is removed from the platform controls when the footswitch is released.*

**Steer Switch** - The steer switch is a thumb-operated switch located at the top of the joystick controller handle. Depressing the switch to the right will steer the wheels to the right. Depressing the switch to the left will steer the wheels to the left.

**Joystick Controller** - This controls drive and lift.

### Steering and Traveling

#### **WARNING**

**DO NOT DRIVE WITH THE PLATFORM ELEVATED EXCEPT ON A SMOOTH, FIRM SURFACE WITHIN THE LIMITS OF THE MAXIMUM OPERATING SLOPE THAT IS FREE OF OBSTRUCTIONS AND HOLES.**

**TO AVOID LOSS OF TRAVEL CONTROL OR UPSET ON GRADES AND SIDESLOPES, DO NOT DRIVE MACHINE ON GRADES OR SIDESLOPES EXCEEDING THOSE SPECIFIED IN SECTION 6.2, MACHINE DIMENSIONS, OR SHOWN IN SECTION 3.9, GRADE AND SIDE-SLOPE.**

**BEFORE DRIVING, LOCATE THE DECALS WITH THE BLACK/WHITE ORIENTATION ARROWS ON THE CHASSIS AND THE PLATFORM CONTROLS. MOVE THE JOYSTICK IN THE DIRECTION OF THE BLACK OR WHITE ARROW THAT MATCHES THE COLOR OF THE ARROW ON THE CHASSIS FOR THE INTENDED DIRECTION OF TRAVEL.**

**IF THE TILT INDICATOR WARNING LIGHT/ALARM IS ACTIVATED WHILE DRIVING WITH PLATFORM RAISED, LOWER PLATFORM COMPLETELY AND DRIVE TO A SMOOTH, FIRM SURFACE WITHIN THE LIMITS OF THE MAXIMUM OPERATING SLOPE.**

1. Place key selector switch at the ground control station to platform operation.
2. Position emergency stop switches, one at the platform and one at the ground control station to the ON position.

## SECTION 3 - MACHINE CONTROLS, INDICATORS, AND OPERATION

### Steering

On the platform control station, position the lift/drive selector switch to the drive/steer position.

To steer the machine, engage trigger switch and the thumb-operated steer rocker switch on the joystick handle. Press to the right for steering right and to the left for steering left. When released, the switch will return to the center (off) position and the wheels will remain in the previously selected position. To return the wheels to the center position, the switch must be activated in the opposite direction until the wheels are centered.



### Traveling Forward and Reverse

Position the platform lift/drive selector switch to drive/steer position. Squeeze the trigger switch on front of the joystick, and move the joystick forward to drive forward or backward to drive in reverse. The drive system is proportional; for additional drive speed, push the joystick further from the neutral position in the direction of travel. Releasing the trigger switch or returning the joystick to center will stop machine movement.

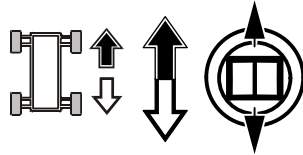

**NOTE:** To ensure proper operation of the desired platform function, move the joystick in the direction of the black or white arrow that matches the color of the arrow on the chassis for the intended direction of travel.

### Raising And Lowering Platform

1. If the machine was shut down, place the key selector switch to the platform position.
2. Position both emergency stop switches to the ON position.
3. Position the lift/drive selector switch to lift.
4. Squeeze and hold the trigger switch and move the joystick back (platform up - white arrow) or move the joystick forward (platform down - black arrow) and hold until desired elevation is reached. Releasing the trigger switch or moving the joystick back to its center position will stop the function being operated.

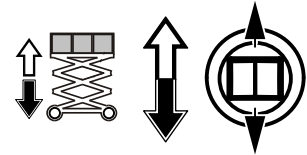

### Arm Guards (If Equipped)

If the machine is equipped with electronic arm guards, the platform will stop lowering at a predetermined height and the machine's beacons will flash at a different rate to warn ground personnel. Machine lowering can continue after a three (3) second delay. Once the lowering function is re-engaged, an audible alarm will sound. After a three second delay, the platform will continue lowering.

### Overload Indicator (LSS)

The Overload Indicator indicates when the platform has been overloaded. An audible alarm will also signal when the platform is overloaded.

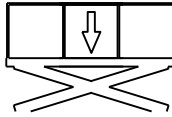

**NOTE:** If the Overload Indicator is illuminated, further elevation will be prevented. Reduce the weight in the platform to not exceed the rated workload indicated on the capacity decal, then the controls will work again.

**NOTE:** When ambient temperatures are below freezing, the LSS will have a reduction in available capacity. This will trigger the LSS before achieving the maximum allowable capacity.

### Tilt Indicator Warning Light and Alarm

A red warning light on the control panel illuminates and an audible alarm sounds when the chassis is at or beyond the tilt cutout settings.



### **WARNING**

**IF THE TILT INDICATOR WARNING LIGHT/ALARM IS ACTIVATED WHEN PLATFORM IS RAISED, LOWER PLATFORM AND DRIVE TO A SMOOTH, FIRM SURFACE WITHIN THE LIMITS OF THE MAXIMUM OPERATING SLOPE.**

### Variable Tilt - Platform Restricted Height Indicator

This indicator shows the maximum allowable platform elevation when the machine is within the limits of the variable tilt envelope. When activated, allowable platform height will be shown in one of three height ranges, depending on the amount of tilt detected by the machine's tilt sensor. See Table 2-2 for tilt angle - platform operating height restrictions.

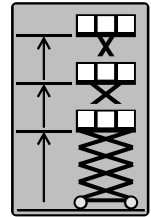

### Horn

This push-button switch, when pressed, permits the operator to warn job site personnel when the machine is operating in the area.

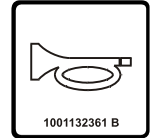

### Alarm

The alarm is mounted on the front of the platform control station and sounds for various machine conditions or warnings such as a system-ready chirp or tilt warning activation.

## SECTION 3 - MACHINE CONTROLS, INDICATORS, AND OPERATION

### Battery Charge Indicator

The battery charge indicator displays the current charge status of the onboard batteries.

- Red LED flashing = batteries depleted
- Red LED on solid = batteries low
- Red LED on and green LEDs on = batteries full charge

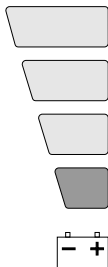

### System Fault Indicator

When this indicator light is flashing, a system fault has occurred, possibly stopping machine operation. Check the MDI Indicator (if equipped) on the Ground Control Station to see if a DTC is displayed.

If the code cannot be cleared by the operator, the machine will require service by a qualified JLG mechanic.



### Indoor/Outdoor Operation Indicator

The Indoor (green) indicator and the Outdoor (yellow) indicator displays the mode in which the machine is currently set to operate.

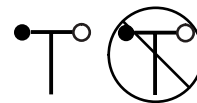

### Indoor/Outdoor Operation Mode Switch

This button toggles between the indoor/outdoor operation modes.

**NOTE:** R2632 machine is rated for INDOOR USE only in AUS market.

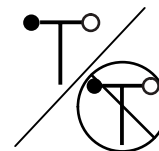

### Low/High Drive Speed

The two-position speed switch controls high or low range drive speed. Use high speed in unobstructed, open, flat, level work areas. Use low speed in close work areas with obstacles, other machinery, or personnel to avoid.

**NOTE:** Drive speed automatically reduces to low drive when the platform is raised above the stowed position, regardless of speed switch position.

**NOTE:** This switch is available on R3246 machines only.

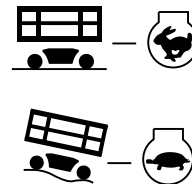

3.9 GRADE AND SIDESLOPE

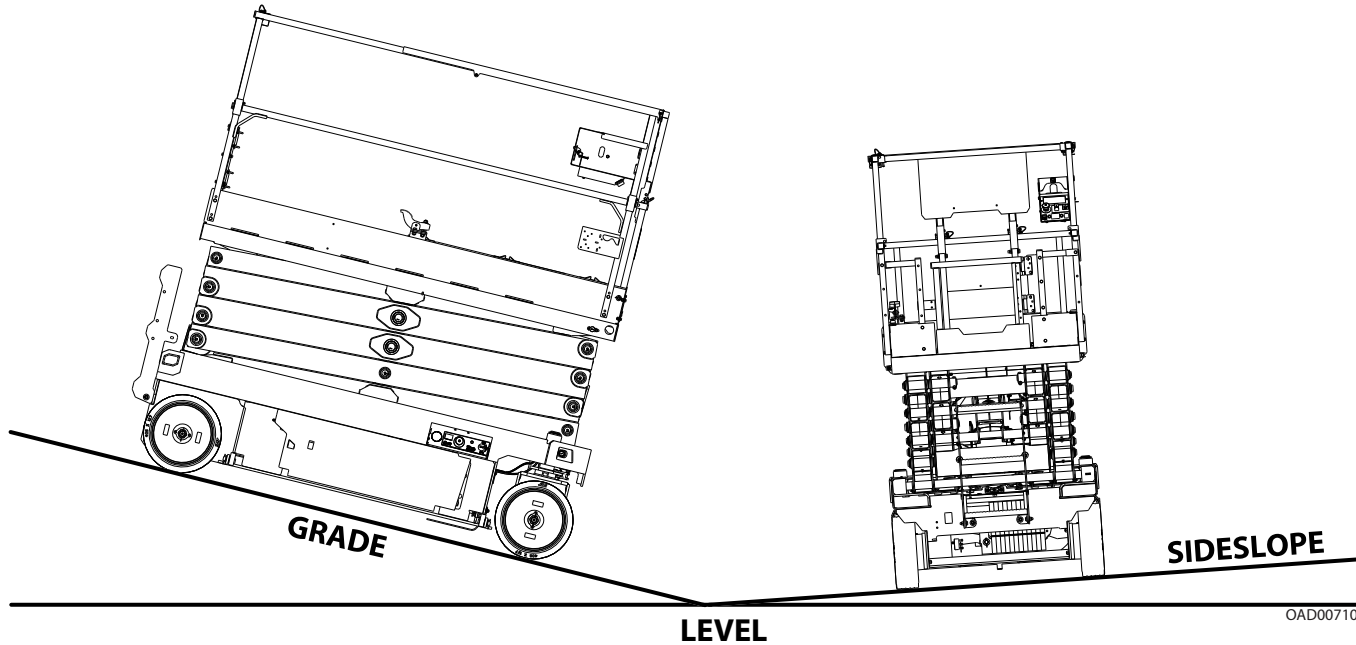

OAD00710

### 3.10 PLATFORM EXTENSION

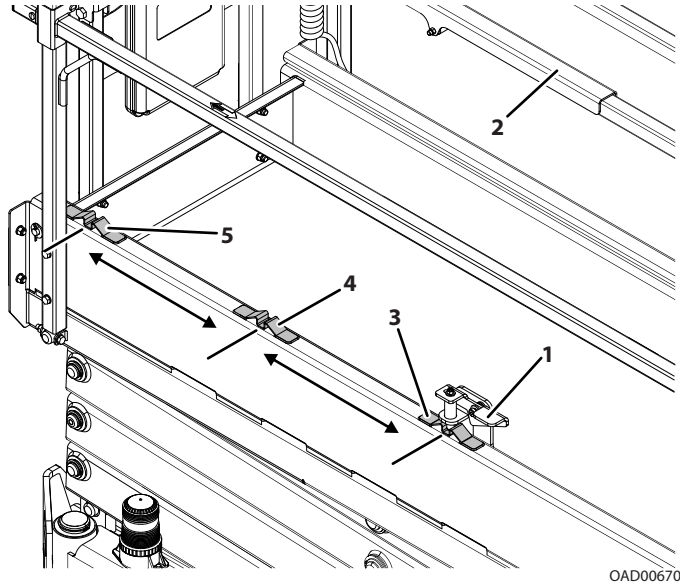

This machine is equipped with an extension deck that allows the operator better access to certain work areas. The deck extension adds length to the front of the platform.

#### **⚠ WARNING**

FOR MAXIMUM CAPACITY OF THE DECK EXTENSION, REFER TO MACHINE DIMENSIONS IN SECTION 6.2, OR REFER TO THE CAPACITY PLACARD ON THE PLATFORM BILLBOARD.

#### **⚠ CAUTION**

DO NOT LOWER THE PLATFORM WITHOUT COMPLETELY RETRACTING THE PLATFORM EXTENSION.

To extend the deck:

1. Press foot down on locking mechanism lever (1). While holding the lever, slide the top handrails (2) until the locking mechanism pin clears the rear platform extension lock (3).
2. Grasp the top handrails (2) of the extension deck and push out until the locking mechanism pin is locked into one of the forward platform extension locks (4 or 5).

To retract the deck:

1. Press foot down on locking mechanism lever (1). Hold down on the lever and pull in the top handrails (2) until the locking mechanism pin clears the forward platform extension locks (5 and 4).
2. Grasp the top handrails (2) of the extension deck and pull back until it hits the stops. Verify the locking mechanism pin locks into the rear platform extension lock (3).



### 3.11 PLATFORM RAILS FOLD-DOWN PROCEDURE (IF EQUIPPED)

#### Platform with Rail-in-Rail Extension Deck

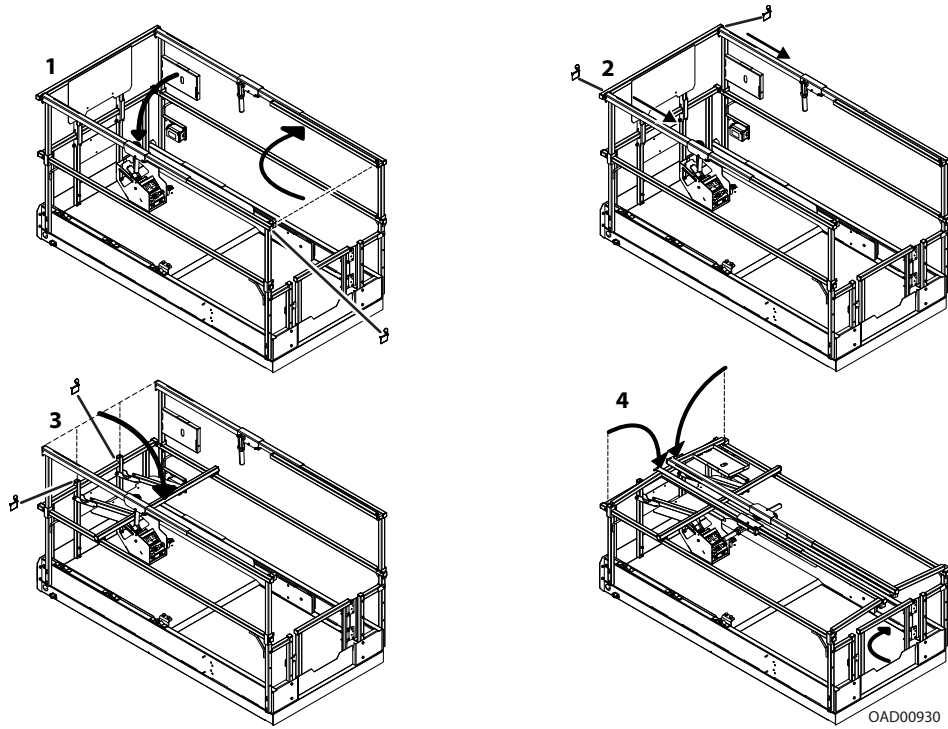

OAD00930

## SECTION 3 - MACHINE CONTROLS, INDICATORS, AND OPERATION

---

### **WARNING**

**ONLY FOLD DOWN THE RAILS WHEN THE MACHINE IS IN THE STOWED (PLATFORM FULLY LOWERED) POSITION. DO NOT RAISE THE PLATFORM WITH THE RAILS FOLDED DOWN. THE RAILS MUST BE IN THE UPRIGHT POSITION AND PROPERLY PINNED WHEN RAISING THE PLATFORM.**

1. Remove the platform control station from its bracket and place on the platform floor. Remove pin from the rear gate top rail, then fold in against the right side rail.
2. Remove the top rail pins at the front of the machine. Slide the deck extension top side rails towards the rear of the machine.

**NOTE:** *Place pins in the lower holes of the extension side top rails before folding main platform side rails down.*

3. Remove the pins at the front mid rails, then fold down the front panel towards the platform floor.
4. Fully open the swing gate and hold. Fold down the right side rail, then fold down the left side rail.

**NOTE:** *For machine R2632, reverse steps 3 and 4. Open and hold the swing gate, then fold down right and left rails, then fold down the front panel.*

To return the rails to the upright position, unfold the rails in the reverse sequence in which they were folded. Firmly pull the rails into position and secure the pins onto the rails.

### **WARNING**

**AFTER THE RAILS HAVE BEEN FOLDED DOWN, USE EXTREME CAUTION WHEN EXITING AND ENTERING THE PLATFORM. ENTER AND EXIT PLATFORM ONLY AT THE GATE AREA AND LADDER PROVIDED.**

### **WARNING**

**IF DRIVING MACHINE WITH THE PLATFORM CONTROL STATION FROM GROUND, DO NOT HANG THE CONTROL BOX ON ANY PART OF THE MACHINE WHILE DRIVING. HOLD THE CONTROL BOX AND KEEP AT LEAST 3 FT (1 M) DISTANCE FROM MACHINE.**

**Platform with Dual Rails Extension Deck**

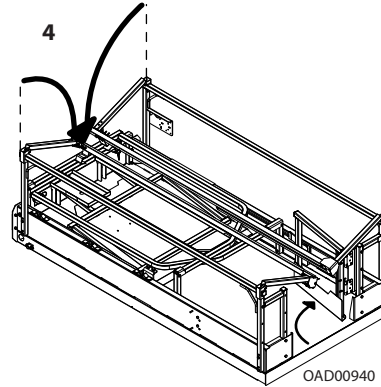
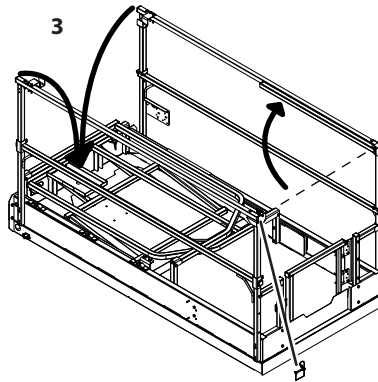
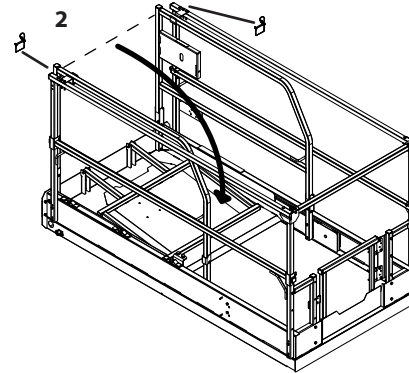
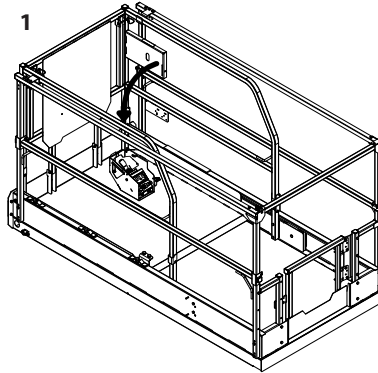

OAD00940

## SECTION 3 - MACHINE CONTROLS, INDICATORS, AND OPERATION

---

### **WARNING**

**ONLY FOLD DOWN THE RAILS WHEN THE MACHINE IS IN THE STOWED (PLATFORM FULLY LOWERED) POSITION. DO NOT RAISE THE PLATFORM WITH THE RAILS FOLDED DOWN. THE RAILS MUST BE IN THE UPRIGHT POSITION AND PROPERLY PINNED WHEN RAISING THE PLATFORM.**

1. Remove the platform control box and place it on the platform deck.
2. Remove two pins at the top front rails, then fold down the front rail panel to the platform floor.
3. Fold down inner extension rails to the platform floor. Remove rail pin at top rear rail and fold in against the right side top rail.
4. Fold down outer platform rails towards platform floor.

To raise the rails back to the upright position, unfold the rails in the reverse sequence they were folded and replace the rail pins into the rails.

**NOTE:** *When setting platform side rails back to upright position be certain the extension platform rail guide is interlocked with the main platform rail once both rails are completely upright.*

### **WARNING**

**AFTER THE RAILS HAVE BEEN FOLDED DOWN, USE EXTREME CAUTION WHEN EXITING AND ENTERING THE PLATFORM. ENTER AND EXIT PLATFORM ONLY AT THE GATE AREA AND LADDER PROVIDED.**

### **WARNING**

**IF DRIVING MACHINE WITH THE PLATFORM CONTROL STATION FROM GROUND, DO NOT HANG THE CONTROL BOX ON ANY PART OF THE MACHINE WHILE DRIVING. HOLD THE CONTROL BOX AND KEEP AT LEAST 3 FT (1 M) DISTANCE FROM MACHINE.**

### 3.12 PLATFORM MANUAL DESCENT

Use the Platform Manual Descent in the event of total power failure to lower the platform using gravity. The red T-handle is located on the left rear of the machine beside the ladder. Look for the instruction decal located beside the T-handle.

1. Locate the manual descent control red T-handle.

**⚠ WARNING**

**KEEP HANDS AND ARMS OUT OF THE PATH OF SCISSOR ARMS AND PLATFORM WHILE LOWERING.**

2. Grasp the T-handle and slowly pull out to lower the scissor arms/platform. When the platform is lowered to the desired level, allow the T-handle to return to its closed position.

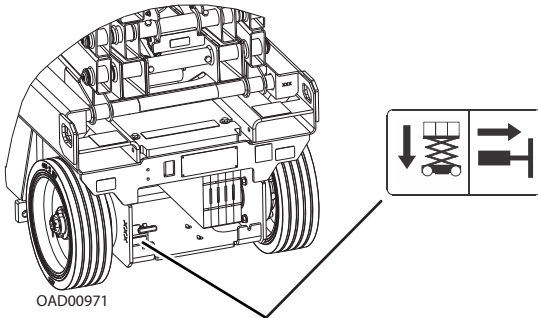

**R2632**

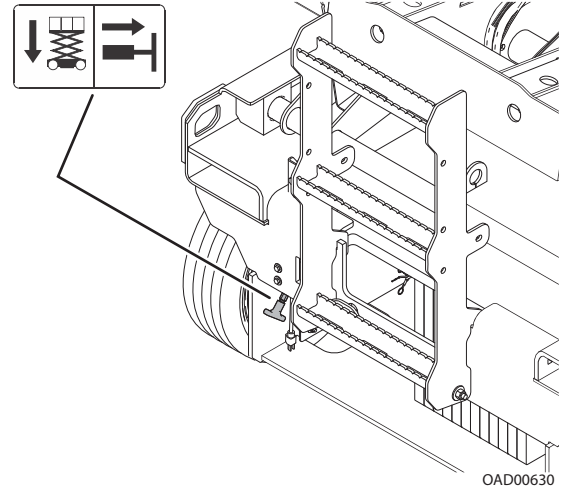

**R3246**

**NOTE:** Ladder removed for illustrative purposes.

### 3.13 PARKING AND STOWING MACHINE

1. Drive the machine to a well-protected and well-ventilated area.
2. Ensure the platform is fully lowered.

#### **NOTICE**

**WHEN THE MACHINE IS SHUT DOWN FOR OVERNIGHT PARKING OR BATTERY CHARGING, THE EMERGENCY STOP AND POWER SELECT SWITCHES MUST BE POSITIONED TO OFF TO PREVENT DRAINING THE BATTERIES.**

3. At the ground control station, turn the platform - ground selector key switch to OFF and remove the key to disable the machine and prevent unauthorized use.

**NOTE:** *For added protection, the platform control station can be secured to its mounting plate. Also the side compartment doors can be secured by placing a padlock through the holes provided just below the door latch on each door.*

At the ground control station, depress emergency stop switch to the off position.

If necessary, cover the platform control box, instruction placards, caution and warning decals so that they will be protected from hostile environment.

Chock at least two wheels when parking the machine for an extended period of time.

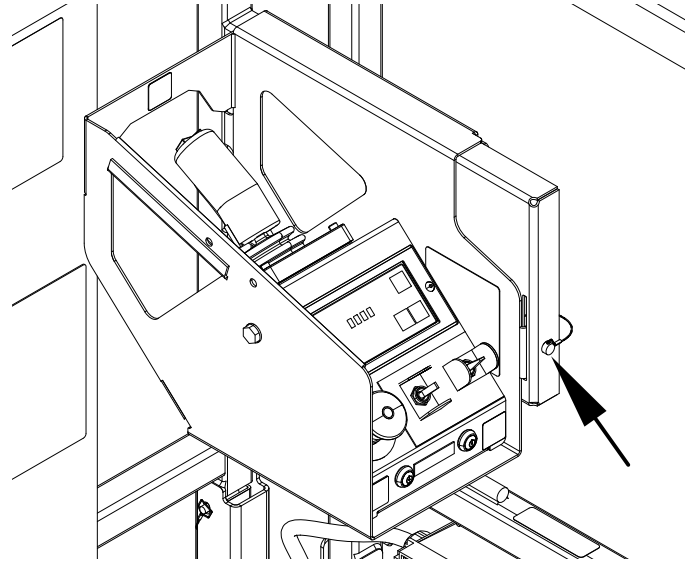

To prevent unauthorized removal, the platform control station can be secured to its mount by replacing the lock pin located on its mounting tab with a keyed or combination lock.

### 3.14 MACHINE LIFTING AND TIE DOWN

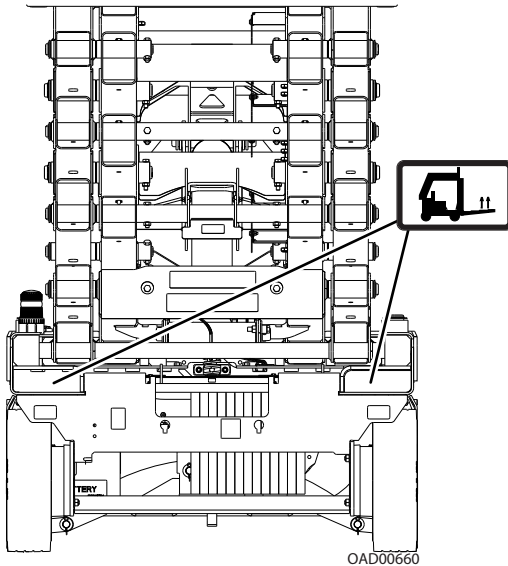

The machine may be lifted using a forklift truck. Lift only using the built-in forklift pockets at the rear of the machine and only with the platform in the stowed position. First adjust the width of the forklift truck lifting tines to fit the machine forklift pockets. Then slide the tines into the forklift pockets and carefully lift machine.

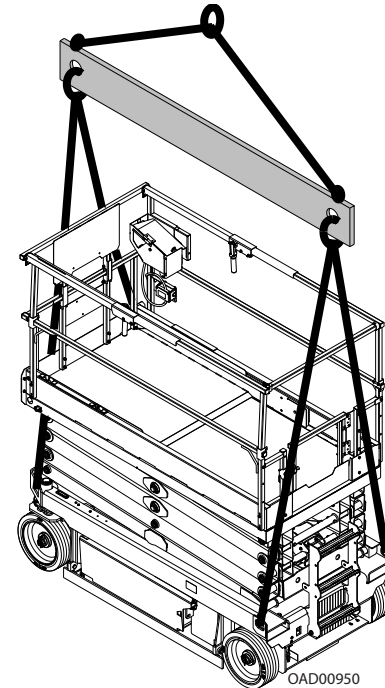

The machine may also be lifted using a spreader bar and four equal length straps or chains capable of supporting the full gross weight of the machine. Lift only using the lifting lugs provided at the four corners of the machine.

## SECTION 3 - MACHINE CONTROLS, INDICATORS, AND OPERATION

When transporting the machine, fully lower the platform (stowed position) and secure the machine to the truck or trailer deck. There

are two tie-down/lift lugs at the rear of the machine, and two tie-downs and one lifting lug at the front of the machine.

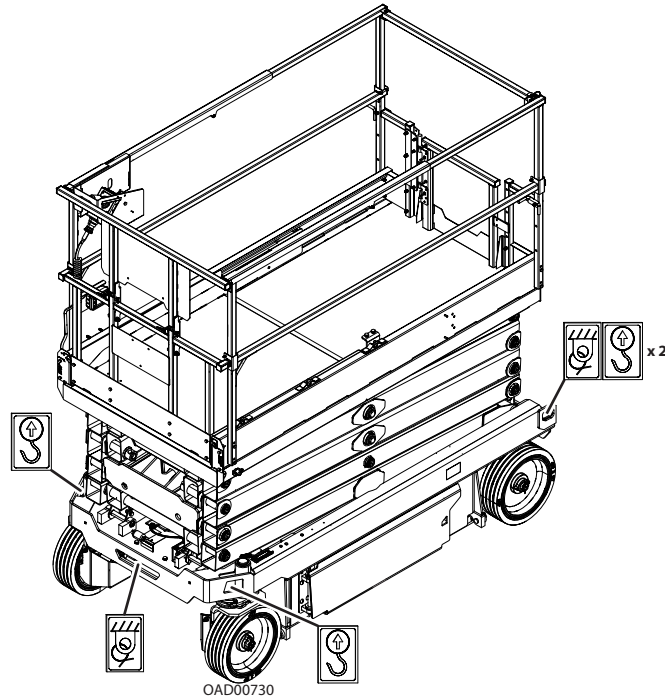



### 3.15 TOWING

It is not recommended to tow this machine except in the event of an emergency such as a machine malfunction or total machine power failure.

#### Hydraulic Brake Release

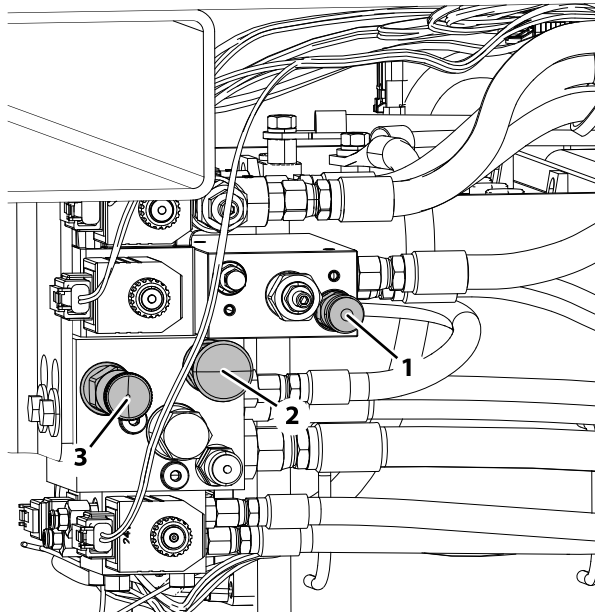

1. Chock wheels or secure machine with tow vehicle.
2. Press in the Emergency Stop switch at the ground control console to turn off power.
3. Open the right side compartment door and locate the main hydraulic control valve.
4. Perform the following to set the drive motor control valve to tow mode:
  - a. On the drive control valve locate the tow mode needle valve knob (1). Screw out the valve until it stops.
  - b. On the main valve body, to release the brakes, push the black brake override button (2) in. A detent will hold the valve in place).
  - c. Pump the red knob (3) until pressure builds, approximately 5 to 10 strokes. The brakes should now be released.
  - d. After towing is complete, chock the wheels. Release the black brake override button (2) and screw the tow mode needle valve knob (1) all the way in to reset the hydraulic brake.

**NOTE:** If machine is disabled to a point where the hydraulic system cannot be operated, the steer circuit will also not be operational. Then the machine will only track in the direction the front wheels are currently positioned.

## SECTION 3 - MACHINE CONTROLS, INDICATORS, AND OPERATION

### Push Button Brake Release (AUS Market Only)

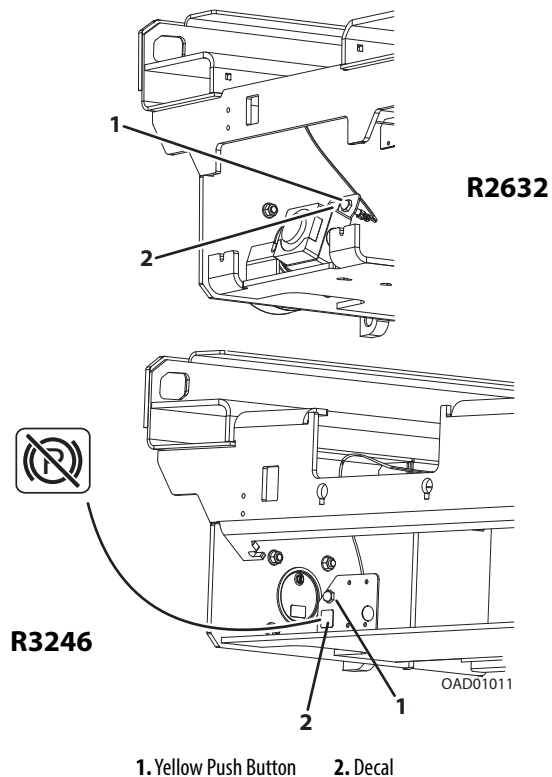

**NOTE:** Some components removed for illustrative purposes.

1. Chock wheels or secure machine with tow vehicle.
2. Pull out emergency stop switch and position the keyswitch to ground mode.
3. Press and hold the yellow button at the rear of the machine for one second to release the brakes. The alarm will sound, then the pump motor will run for several seconds to release the brakes.
4. To reset the brakes, press the yellow button again.

## **SECTION 4. EMERGENCY PROCEDURES**

### **4.1 GENERAL INFORMATION**

This section explains the steps to be taken in case of an emergency situation during operation.

### **4.2 INCIDENT NOTIFICATION**

JLG Industries, Inc. must be notified immediately of any incident involving a JLG product. Even if no injury or property damage is evident, JLG must be contacted by telephone and provided with all necessary details.

- USA: 877-JLG-SAFE (554-7233)
- EUROPE: (32) 0 89 84 82 20
- AUSTRALIA: (61) 2 65 811111
- E-mail: productsafety@jlg.com

Failure to notify the manufacturer of an incident involving a JLG Industries product within 48 hours of such an occurrence may void any warranty consideration on that particular machine.

### **NOTICE**

**FOLLOWING ANY INCIDENT, THOROUGHLY INSPECT THE MACHINE. DO NOT ELEVATE THE PLATFORM UNTIL IT IS CERTAIN THAT ALL DAMAGE HAS BEEN REPAIRED AND THAT ALL CONTROLS ARE OPERATING CORRECTLY. TEST ALL FUNCTIONS FIRST FROM THE GROUND CONTROL STATION THEN FROM THE PLATFORM CONTROL CONSOLE.**

### **4.3 EMERGENCY OPERATION**

#### **Operator Unable to Control Machine**

If the platform operator is unable to operate or control the machine:

1. Other personnel should operate the machine from ground controls only as required.
2. Only qualified personnel in the platform may use the platform controls. **DO NOT CONTINUE OPERATION IF CONTROLS DO NOT FUNCTION PROPERLY.**
3. Rescue equipment can be used to remove the platform occupant(s). Cranes and forklifts can be used to stabilize motion of the machine.

#### **Righting of Tipped Machine**

A fork truck of suitable capacity or equivalent equipment should be placed under the elevated side of the chassis, with a crane or other suitable lifting equipment used to lift the platform while the chassis is lowered by the forklift or other equipment.

#### **Platform Caught Overhead**

If the platform becomes jammed or snagged in overhead structures or equipment, do the following:

1. Shut off the machine.
2. Rescue all people in the platform before freeing the machine. Personnel must be out of the platform before operating any controls on the machine.
3. Use cranes, forklifts or other equipment to stabilize motion of the machine to prevent a tip over as required.
4. From the ground controls, carefully free the platform from the object.
5. Once clear, restart the machine and return the platform to a safe position.
6. Inspect the machine for damage. If the machine is damaged or does not operate properly, turn off the machine immediately. Report the problem to the proper maintenance personnel. Do not operate the machine until it is declared safe for operation.

## 4.4 PLATFORM MANUAL DESCENT

Use the Platform Manual Descent in the event of total power failure to lower the platform using gravity. The red T-handle is located on the left rear of the machine beside the ladder. Look for the instruction decal located beside the T-handle.

1. Locate the manual descent control red T-handle.



**KEEP HANDS AND ARMS OUT OF THE PATH OF SCISSOR ARMS AND PLATFORM WHILE LOWERING.**

2. Grasp the T-handle and slowly pull out to lower the scissor arms/platform. When the platform is lowered to the desired level, allow the T-handle to return to its closed position.

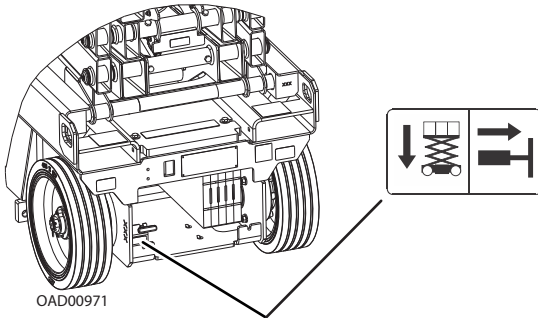

**R2632**

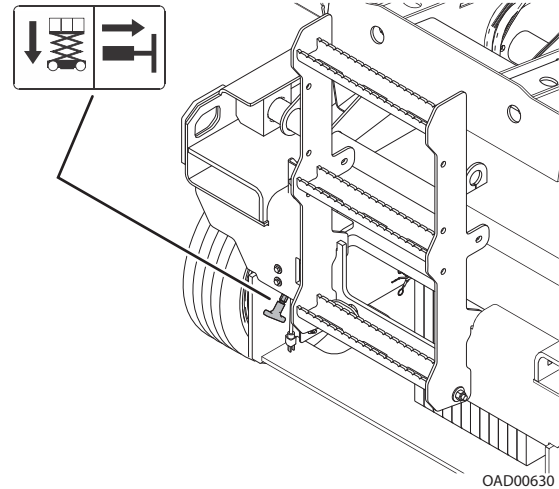

**R3246**

**NOTE:** Ladder removed for illustrative purposes.



## SECTION 5. ACCESSORIES

## 5.1 AVAILABLE ACCESSORIES

ACCESSORY	MARKET							
	ANSI (USA Only)	ANSI	CSA	CE	AUS	China	Korea	Japan
DC/AC Power Inverter	✓							
Pipe Racks	✓	✓	✓	✓	✓	✓	✓	✓
Anti-Vandalism Package	✓	✓	✓	✓	✓	✓	✓	✓
Rail-Mounted Platform Extension Handles	✓	✓	✓	✓	✓	✓	✓	✓
Footswitch							✓	✓
Magnetic Gate Latch	✓	✓	✓	✓	✓	✓	✓	✓
JLG™ Mobile Control	✓		✓	✓				

**5.2 OPTIONS/ACCESSORIES RELATIONSHIP TABLE**

ACCESSORY	COMPATIBLE WITH <i>(Refer to Note)</i>	INCOMPATIBLE WITH
DC/AC Power Inverter	All	None
Pipe Racks	All	Dual Rails (R2632 only)
Anti-Vandalism Package	All	None
Rail-Mounted Platform Extension Handles	Inverter, Pipe Racks, Anti-Vandalism Package, Footswitch, Magnetic Gate Latch	Dual Rails
Footswitch	All	None
Magnetic Gate Switch	All	None
JLG Mobile Control	All	None
<b>NOTE:</b> Any accessory not listed under "COMPATIBLE WITH" is assumed to be incompatible.		

1001218523-H



### 5.3 DC/AC POWER INVERTER

The DC/AC Power Inverter converts DC voltage from the onboard system batteries to AC voltage for use at the platform AC output receptacle. The inverter module is mounted on the battery compartment door behind a protective cover.

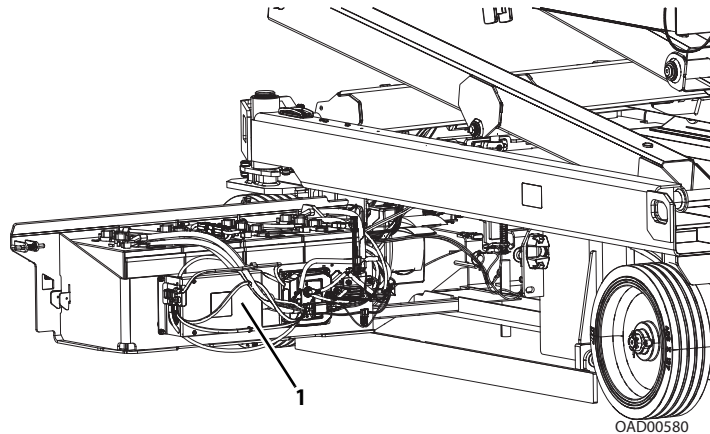

1. Inverter Assembly

OAD00580

### Specifications

DESCRIPTION	SPECIFICATION
Electrical System Voltage (DC)	24V
Power Inverter	Power Bright
DC Input	DC Input Voltage Operating Temperature
	20 to 30VDC -4° F (-20°C) to 113° F (+45°C)
AC Output	Output Power (Continuous) Output Power (Surge) Output Power (AC) Output Voltage (AC) Output Frequency Type
	900W 1800W 7.5A 117V +/- 10% 60 Hz Modified Sine Wave
Protection	Out put Reverse DC Polarity
	3 X 25A Replaceable Fuse

### Safety Precautions

- Do not connect the inverter to any power source other than 24V, including any AC power source.
- This system presents a danger of shock or electrocution. Treat inverter output equally to commercial AC power.
- Do not allow water or other liquids to contact the inverter.

### Preparation and Inspection

- Do not use appliances with damaged or wet cords.
- Route appliance cords and extension cords to prevent accidental pinching, crushing, abrading, and tripping hazards.
- Do not use the inverter near flammable materials or in any locations that may accumulate flammable fumes or gases. This is an electrical device that can briefly spark when electrical connections are made or broken.

### Operation

1. Set the built-in inverter ON/OFF switch to the ON position.
2. At the ground control console, set the inverter ON/OFF switch to the ON position.

**NOTE:** Only plug in tools or appliances rated within the maximum output wattage at the platform AC receptacle.

### 5.4 PIPE RACKS

Pipe Racks provide a way to store pipe or conduit inside the platform while avoiding rail damage and optimizing platform utility when transporting material to an elevated site. It consists of two racks attached to the platform handrails with adjustable straps that secure the load in place.

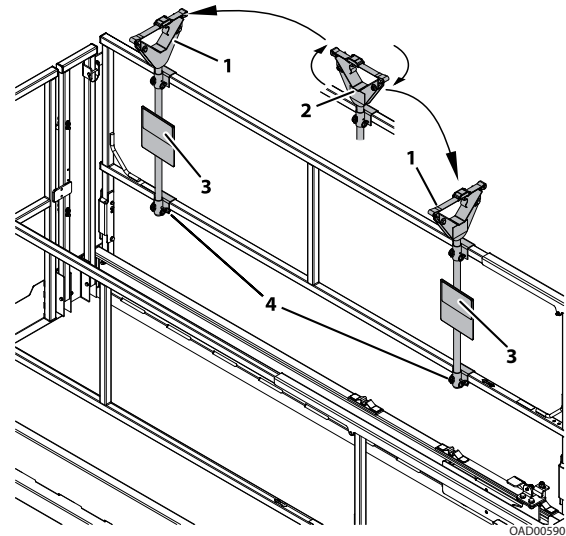

1. Working Position
2. Stowed Position

3. Capacity Decal
4. Work/Stow Locking Pins

## Safety Precautions

### WARNING

THIS ACCESSORY AFFECTS OVERALL PLATFORM CAPACITY. REFER TO CAPACITY DECAL AND ADJUST ACCORDINGLY. DO NOT OVERLOAD PIPE RACKS.

### NOTICE

RETRACT PLATFORM EXTENSION BEFORE ATTACHING PIPE RACKS AND LOADING MATERIAL.

### NOTICE

MAXIMUM WEIGHT IN RACKS IS 45 KG (100 LB) EVENLY DISTRIBUTED BETWEEN RACKS. MAXIMUM LENGTH IS 6 M (20 FT). MAXIMUM CIRCUMFERENCE OF MATERIAL IS 180 MM (7.1 IN) PER PIPE.

- Ensure no personnel are beneath the platform.
- Do not exit the platform over the rails, or stand on the rails.
- Do not drive the machine without material secured.
- Return the racks to the stowed position when not in use.

**NOTE:** *Pipe Racks are not available for R2632 machines with dual rails.*

## Preparation and Inspection

- Ensure all components are secured to the platform.
- Check for missing or damaged components. Replace if necessary.
- Check for loose nuts and bolts. If necessary, torque according to the Torque Chart specifications in Section 1 of the Service Manual.
- Replace missing or illegible decals.
- Replace any torn or frayed straps.

## Operation

1. To prepare racks for loading, remove work/stow locking pins, rotate each rack 90 degrees from stowed to working position, and secure with the locking pins.
2. Place material onto racks with weight evenly distributed between both racks. Do not exceed the rated capacity stated on the decal.
3. Route the tie-down straps at each end across loaded material and tighten.
4. To remove material, loosen and remove tie-down straps, then carefully remove material from racks.

**NOTE:** *Reinstall tie-down straps across any remaining material before continuing machine operations.*

5. When not in use, remove locking pins, rotate racks 90 degrees to the stowed position, and reinstall locking pins.

**5.5 ANTI-VANDALISM PACKAGE**

The Anti-Vandalism Package consists of two lockable covers for the Platform and Ground Control Stations that prevent unauthorized use of the machine. Locks are not provided with this kit.

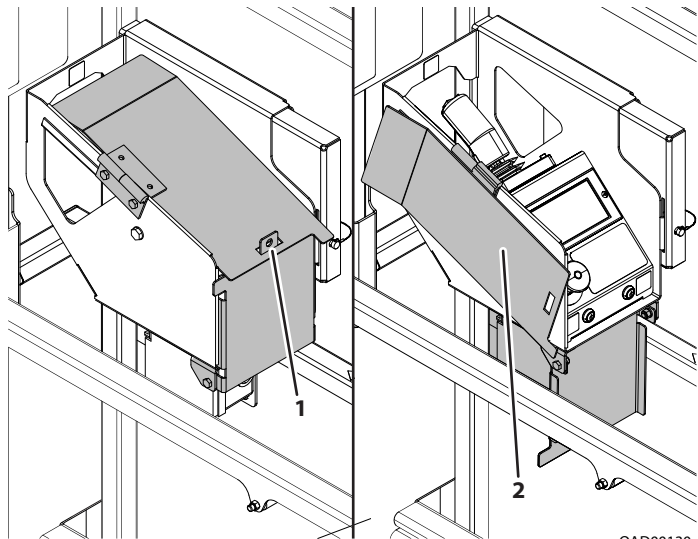

OAD00130

**Platform Control Station**

- 1. Lock Position (Closed)
- 2. Cover Open

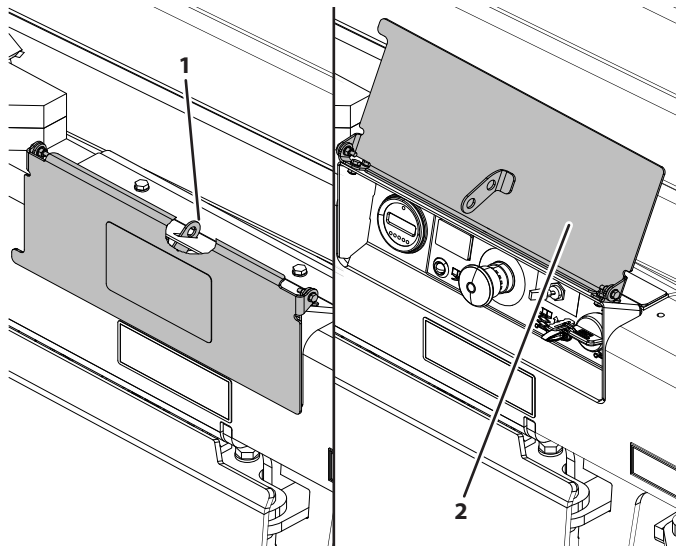

**Ground Control Station**

- 1. Lock Position (Closed)
- 2. Cover Open

## 5.6 RAIL-MOUNTED PLATFORM EXTENSION HANDLES

Rail-mounted Platform Extension Handles are mounted to the top rails of the extension platform at the roller tabs. When rotated up 90°, the handles provide the operator an optional grip to push the extension platform out from the stowed position.

### Operation

1. Swing both extension handles up 90° to extension position.
2. While standing on the main platform, release the extension platform lock mechanism with one foot.
3. Grasp both handles and push platform extension out until locked in either of the two other locked extension positions.

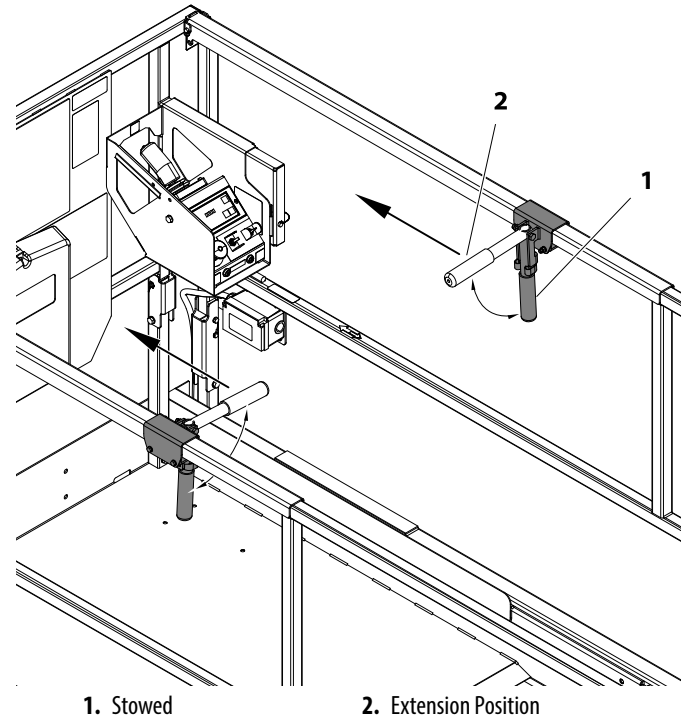

### 5.7 FOOTSWITCH

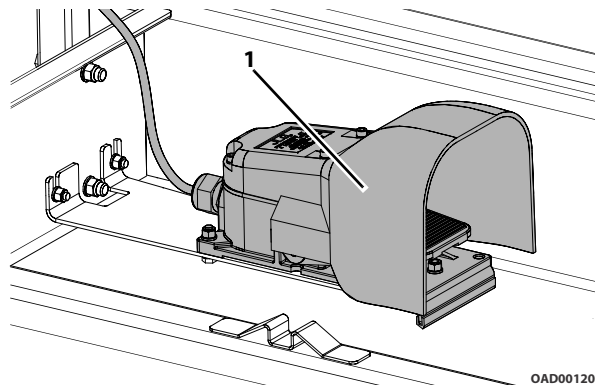

1. Footswitch Assembly

The Footswitch serves as another enable switch in the function control circuit. It must be depressed in sequence with the platform control joystick trigger switch to enable operation of machine functions when using the platform controls. Power is removed from the platform controls when the footswitch is released.

**NOTE:** This accessory is only available in Japanese and Korean markets.

### Operation

To operate a function, engage the footswitch and joystick trigger in any sequence.

### 5.8 MAGNETIC GATE LATCH

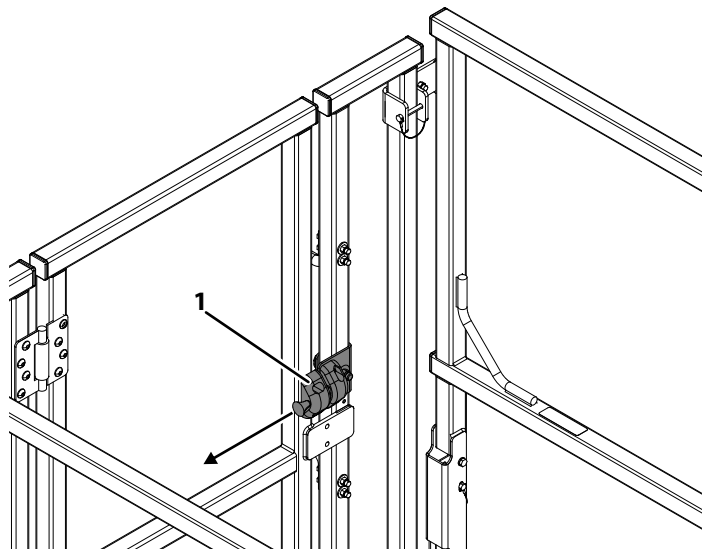

1. Magnetic Gate Latch Assembly

The Magnetic Gate Latch ensures the platform gate latches securely when closed.

1. Grasp handle and pull out to unlatch. Swing open the gate.

## 5.9 JLG™ MOBILE CONTROL

The JLG Mobile Control application allows machine operators to drive remotely from a Bluetooth® equipped hand-held mobile device.

Prior to operation, the operator must scan the QR code on the machine with a mobile device equipped with the JLG Mobile Control application. This pairs the Mobile Control module on the machine with the mobile device to allow remote operation.

**NOTE:** *The Bluetooth word mark and logos are registered trademarks owned by Bluetooth SIG, Inc. and any use of such marks by JLG is under license. Other trademarks and trade names are those of their respective owners.*

## Download

Visit the Apple Store®, Google Play®, or <https://www.JLG.com/mobilecontrol> in order to download the JLG Mobile Control application.



OAD00850

### Operation

Download, read, and understand the JLG Mobile Control Supplement Manual from <https://www.JLG.com/mobilecontrol> prior to using the JLG Mobile Control.

#### **⚠ WARNING**

**NEVER DRIVE THE MACHINE USING JLG MOBILE CONTROL WHILE STANDING IN THE PLATFORM, OR WITHOUT CLEAR LINE-OF-SIGHT BETWEEN THE MACHINE AND ITS TRAVEL PATH, AS SERIOUS INJURY COULD OCCUR TO OPERATOR OR BYSTANDER.**

### Document Resources

Access to application related documentation.

1. Select Settings (a) from the Home Screen
2. Select either:
  - b. JLG Mobile Control Supplement manual
  - c. Legal Statements (FCC, ISED)
  - d. Regulatory Statements (EULAs, DoC)

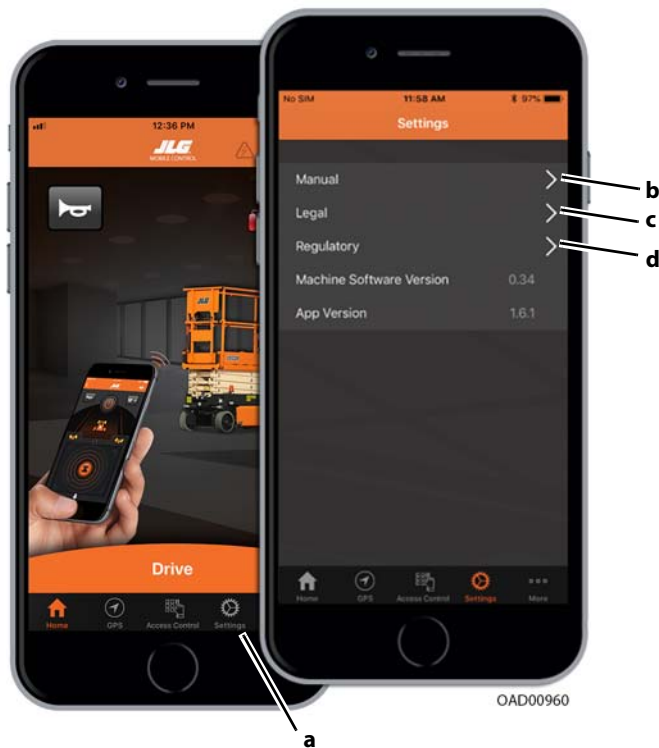



## SECTION 6. SPECIFICATIONS AND OPERATOR MAINTENANCE

### 6.1 GENERAL INFORMATION

This section provides additional necessary information to the operator for proper machine operation and maintenance.

The maintenance portion of this section is intended to assist the machine operator to perform only daily maintenance tasks and does not replace the more thorough Preventive Maintenance and Inspection Schedule in the Service and Maintenance Manual.

#### Other Publications Available Specific to this Machine

Service and Maintenance Manual .....	31215091
Illustrated Parts Manual (R2632) .....	31215092
Illustrated Parts Manual (R3246) .....	31215093

### Serial Number Identification

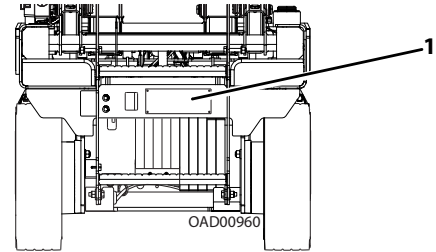

1. Serial Number Plate (R2632)

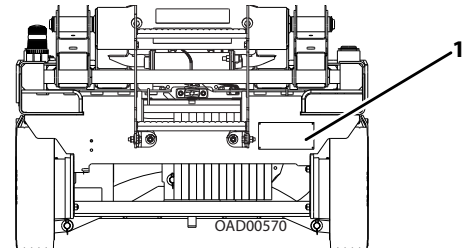

1. Serial Number Plate (R3246)

## SECTION 6 - SPECIFICATIONS AND OPERATOR MAINTENANCE

### 6.2 SUPPLEMENTAL INFORMATION

The following information is provided in accordance with the requirements of the European Machinery Directive 2006/42/EC and is only applicable to CE machines.

For electric-powered machines, equivalent continuous A-Weighted sound pressure level at work platform is less than 70dB(A).

For combustion engine powered machines, guaranteed Sound Power Level (LWA) per European Directive 2000/ 14/EC (Noise Emission in the Environment by Equipment for Use Outdoors) based on test methods in accordance with Annex III, Part B, Method 1 and 0 of the directive, is 109 dB.

The vibration total value to which the hand-arm system is subjected does not exceed 2,5 m/s<sup>2</sup>. The highest root mean square value of weighted acceleration to which the whole body is subjected does not exceed 0.5 m/s<sup>2</sup>.

### 6.3 MACHINE SPECIFICATIONS

#### Operating Specifications

DESCRIPTION	R2632	R3246	
Gross Vehicle Weight	All Markets AUS Only	4,280 lb (1,941 kg) 4,280 lb (1,941 kg)	5,410 lb (2,454 kg) 5,510 lb (2,499 kg)
Maximum Working Height		31.5 ft (9.6 m)	38 ft (11.6 m)
Lift Up Time	No Load Rated Load	28 - 38 sec 32 - 46 sec	43 - 51 sec 46 - 54 sec
Lift Down Time	No Load Rated Load	32 - 40 sec 24 - 34 sec	40 - 48 sec 33 - 41 sec
Ground Clearance	PHP Deployed PHP Retracted Breakover Angle	0.91 in (23 mm) 3.9 in (98 mm) 12°	
Electronic Arm Guard Pause Height (CE/GB only)		66 in (1.68 m)	73 in (1.85 m)
High Drive Speed (Forward/Reverse)		2.0 mph (3.2 kph)	2.2 mph (3.5 kph)
Elevated Drive Platform Height		55 in (1.40 m)	65 in (1.65 m)
Elevated Drive Speed (Forward/Reverse)		0.5 mph (0.8 kph)	
Maximum Stowed Travel Grade (Gradeability)		25% (14°)	
Maximum Stowed Travel Grade (Sideslope)		8.75% (5°)	
Maximum Tire Load		1,373 lb (623 kg)	2,150 lb (975 kg)
Occupied Floor Area		21 ft <sup>2</sup> (1.95 m <sup>2</sup> )	30.1 ft <sup>2</sup> (2.80 m <sup>2</sup> )
Ground Bearing Pressure		92 psi	131 psi

**Machine Dimensions**

DESCRIPTION	R2632	R3246
Maximum Platform Height		
Indoor/Outdoor (All Markets)	--	32 ft (9.75 m)
Indoor (All Markets)	25.5 ft (7.77 m)	--
Outdoor (All Markets Except AUS)	21 ft (6.40 m)	--
Overall Machine Height (Stowed)		
Telescope Rails	7.30 ft (2.23 m)	7.96 ft (2.43 m)
Dual Rails	7.29 ft (2.22 m)	8.03 ft (2.45 m)
Rails Folded	5.81 ft (1.77 m)	6.47 ft (1.97 m)
Overall Machine Height (Elevated)		
Telescope Rails	29.17 ft (8.89 m)	35.72 ft (10.89 m)
Dual Rails	29.23 ft (8.91 m)	35.78 ft (10.91 m)
Platform Height (Ground to Platform Floor)		
Stowed	3.63 ft (1.11 m)	4.24 ft (1.29 m)
Elevated	25.5 ft (7.77 m)	32 ft (9.75 m)
Safety Prop Engaged	7.15 ft (2.18 m)	8.50 ft (2.59 m)
Rail Height (Platform Floor to Top of Rail)		
Telescope Rails	3.66 ft (1.12 m)	3.72 ft (1.13 m)
Dual Rails	3.66 ft (1.12 m)	3.78 ft (1.15 m)
Overall Machine Width	32 in (81.3 cm)	46 in (117 cm)
Overall Machine Length (with Ladder)	7.86 ft (2.40 m)	
Extension Deck Length	34 in (0.86 m)	3 ft (0.91 m)
Wheelbase	74.2 in (188.5 cm)	

**Maximum Allowable Operating Slope**

DESCRIPTION	R2632	R3246
Front to Back:	3.5°	
Side to Side:	1.5°	

**Platform Capacities**

DESCRIPTION	R2632	R3246
Operating Personnel		
Indoor	2 persons	2 persons
Outdoor	1 person	1 person
Outdoor (AUS Only)	*	1 person
Platform Rated Load		
Indoor	507 lb (230 kg)	705 lb (320 kg)
Outdoor (All Markets Except AUS)	275 lb (125 kg)	507 lb (230 kg)
Outdoor (AUS Only)*	*	705 lb (320 kg)
Extension Deck Rated Load	265 lb (120 kg)	
Maximum Operating Wind Speed		
Indoor	0 mph (0 m/s)	
Outdoor	28 mph (12.5 m/s)	
Maximum Horizontal Side Force		
Indoor	90 lb (400 N)	
Outdoor	45 lb (200 N)	
<b>* Note:</b> Machine R2632 does not have outdoor functionality in the AUS market.		

**NOTE:** *INDOOR USE* is use of a MEWP in areas shielded from wind so that there is no wind. *OUTDOOR USE* is use of a MEWP in an environment that can be exposed to wind.

## SECTION 6 - SPECIFICATIONS AND OPERATOR MAINTENANCE

### Tires

DESCRIPTION	R2632	R3246
Size	16 in (406 mm) x 5 in (127 mm)	
Wheel Nut Torque (2 in [51 mm] Slotted Nut with Cotter Pin)	150 ft.lb (203 Nm)	

### Batteries

DESCRIPTION	R2632 & R3246		
	Lead Acid	Lead Acid (Extended Range)	AGM
Voltage (24V System)	6V per battery		
Amp Hour Rating (@ 20 hr)	225 Ah	255 Ah	213 Ah
Reserve Capacity	447 min	570 min	492 min
Weight (per battery)	63 lb (28.6 kg)	75 lb (34 kg)	66 lb (30 kg)

## 6.4 BATTERY CHARGER

### Specifications

DESCRIPTION	SPECIFICATIONS		
Electrical System Voltage (DC)	24V		
Battery Charger	Delta-Q	PRO - Eagle Performance Series	Green Power - Pylon International
<b>Input</b> AC Input Voltage Nominal AC Input Voltage Input Frequency Max. AC Input Current Ingress Protection Operating Temperature  <b>Output</b> Nominal DC Output Voltage Max. DC Output Voltage Max DC Output Current Max. Interlock Current  <b>Protection</b> Output Reverse Polarity Output Short Circuit AC Overload DC Overload	85-270V AC 100VAC / 240VAC RMS 50 - 60Hz 7.5A IP66 NEMA4 Type 4 -40°F (-40°C) to 149°F (+65°C)	108-132V AC 120VAC RMS 45 - 65Hz 12A IP35 -22°F (-30°C) to 122°F (+50°C)	100-240V AC — — 45 - 65Hz 8.5A IP66 -4°F (-20°C) to 122°F (+50°C)
	24V 36V 27.1A 1A @ 24V	24V 31.92V 25A 1A @ 24V	24V 34V 30A 1A @ 24V
	Electronic Protection-Auto Reset Current Limited Current Limited Current Limited	Electronic Protection-Auto Reset Electronic Protection-Auto Reset Branch Circuit Protection Current Limited	Electronic Protection-Auto Reset Electronic Protection-Auto Reset Current Limited Current Limited

## SECTION 6 - SPECIFICATIONS AND OPERATOR MAINTENANCE

### Delta-Q

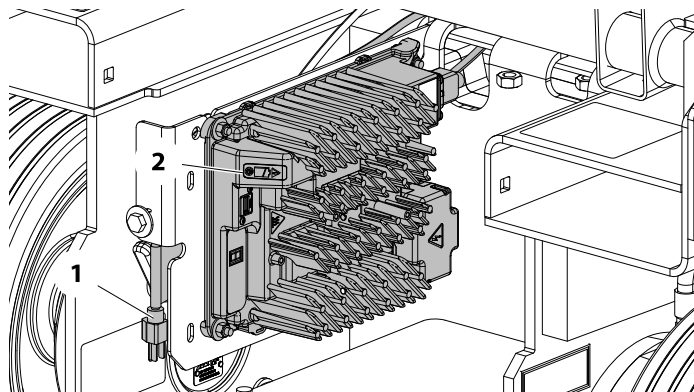

1. AC Voltage Input Plug      2. Charge Indicator LEDs

- **AC Power On:** Blue LED on
- **Low State of Charge:** Bottom Panel - Green LED flashing;  
Top Panel - Green LED off
- **High State of Charge:** Bottom Panel - Green LED on;  
Top Panel - Green LED flashing
- **Charge Complete:** Bottom Panel - Green LED on;  
Top Panel - Green LED on
- **Fault Indicator:** Red LED on
- **External Error Condition Caution:** Amber LED flashing

### Eagle Performance

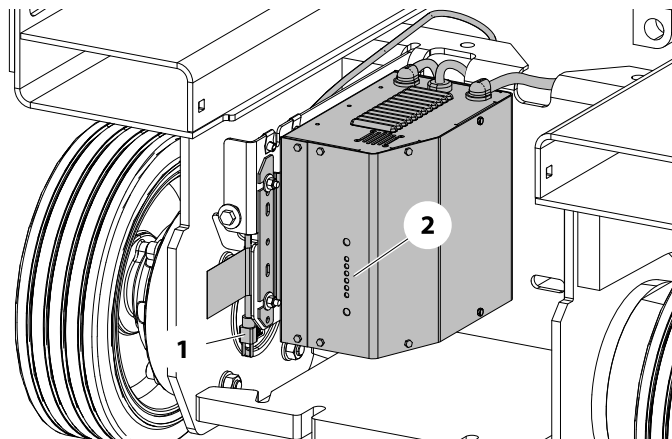

1. AC Voltage Input Cable      2. Charge Indicator LEDs

- **Battery Type Indicator:** Yellow LED on
- **Battery Charging:** 30%-60%-90% Red LED on
- **Charge Complete:** Green LED on
- **No Battery Detected:** 30% Red LED blinking
- **Overall Timer Shutdown:** 30-60-90% Red LEDs blinking
- **Internal OverTemp Shutdown:** 30 - 90% Red LEDs blinking

**Green Power (China (GB) Only)**

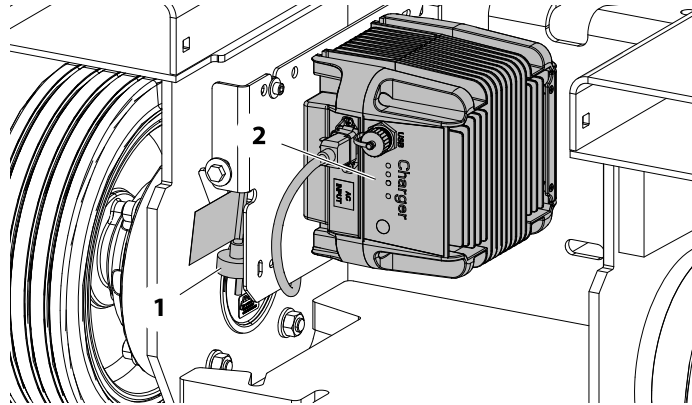

1. AC Voltage Input Cable      2. Charge Indicator LEDs

- **Battery Charging:** Yellow LED - AGM - flashes quickly; Flooded - remains on / AGM flooded - flashes slowly
- **Charge Complete:** Green LED on
- **Fault Indicator:** Red LED on
- **Performing Self-Diagnostic:** Yellow and green LEDs flashing simultaneously

**6.5 LUBRICATION**

**Capacities**

COMPONENT	R2632	R3246
Hydraulic Reservoir (at Full mark)	4 gal (15 L)	
Hydraulic System (Including Reservoir)	4.75 gal (18 L)	5.5 gal (21 L)

**Specifications**

KEY	SPECIFICATIONS
MPG	Multipurpose Grease having a minimum dripping point of 350° F. Excellent water resistance and adhesive qualities, and being of extreme pressure type. (Timken OK 40 pounds minimum.)
EPGL	Extreme Pressure Gear Lube (oil) meeting API service classification GL-5 or MIL-Spec MIL-L-2105.
HO	JLG Recommends - Mobil - Mobilfluid 424 Mobil EAL ENVIRONSYN H 32 Mobil SHC HYDRAULIC EAL 32 EAL and SHC are compatible with each other.

## SECTION 6 - SPECIFICATIONS AND OPERATOR MAINTENANCE

### Hydraulic Oil Operating Temperature Chart

 IN THIS REGION FUNCTION SPEEDS & BATTERY LIFE MAY BE SIGNIFICANTLY REDUCED

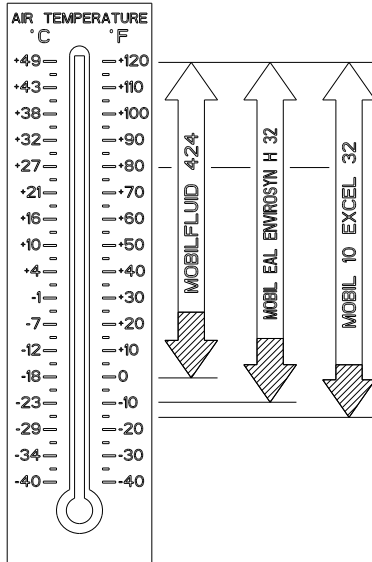

Fluid	Properties		Base			Classification				
	Description	Viscosity @ 40°C (Cst. Typical)	Visc Index	Mineral Oils	Vegetable Oils	Synthetic	Synthetic Polyol Esters	Readily Biodegradable*	Virtually Non-toxic**	Fire Resistant***
Mobilfluid 424		55	145	X						
Mobil EAL EnviroSyn H 32		33	147			X		X		
Mobil 10 Excel 32		32	164	X					X	
Mobil 10 Excel 15		15	168	X					X	

- \* Readily biodegradable classification indicates one of the following:  
CO2 Conversion > 60% per EPA 560/6-82-003  
CO2 Conversion > 80% per CEC-L-33-A-93
- \*\* Virtually Non-toxic classification indicates an LC50 > 5000 ppm per OECD 203
- \*\*\* Fire Resistant classification indicates Factory Mutual Research Corp. (FMRC) Approval

NOTICE:  
MACHINE OPERATION USING NON-JLG APPROVED HYDRAULIC FLUIDS OR OPERATION OUTSIDE OF THE TEMPERATURE BOUNDARIES OUTLINED IN THE "HYDRAULIC FLUID OPERATION CHART" MAY RESULT IN PREMATURE WEAR OR DAMAGE TO COMPONENTS OF THE HYDRAULIC SYSTEM.

SOME FLUIDS MAY NOT BE AVAILABLE FROM THE FACTORY

1001219909-D  
OAD00811



## **6.6 OPERATOR MAINTENANCE**

### **Engaging the Safety Prop**

**⚠ WARNING**

**NEVER WORK UNDER AN ELEVATED PLATFORM UNTIL IT HAS BEEN RESTRAINED FROM MOVEMENT WITH THE SAFETY PROP, BLOCKING, OR OVERHEAD SLING.**

**⚠ CAUTION**

**THE SAFETY PROP MUST BE USED WHENEVER MAINTENANCE PERFORMED ON THE MACHINE REQUIRES THE SCISSOR ARMS BE RAISED. ENSURE THERE IS NO LOAD IN THE PLATFORM.**

Before operator maintenance can be conducted, engage the machine's red safety prop. The safety prop is located at the rear of the machine in the armstack.

To engage the safety prop:

1. From the Ground Control Station, raise the platform approximately 9 ft (2.7 m).
2. At rear of machine, pull red safety prop into the vertical position.
3. Lower the platform until the crossbar above the prop comes into contact with the prop.
4. Ensure all downward movement stops when safety prop is engaged.

To disengage the safety prop:

1. Raise the platform enough to release the safety prop.
2. Push in the safety prop.

3. Lower the platform to the stowed position.

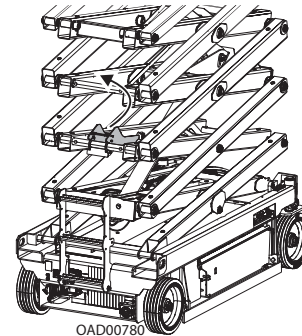

**Prop Disengaged**

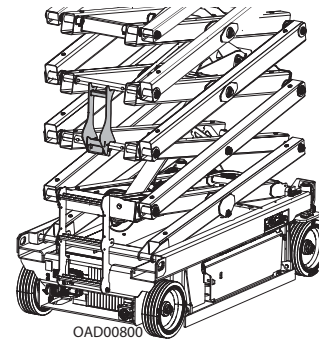

**Prop Engaged**

## SECTION 6 - SPECIFICATIONS AND OPERATOR MAINTENANCE

### Hydraulic Oil Check Procedure

To ensure proper operation of the machine, the hydraulic oil must be checked daily.

Check the hydraulic oil level only when the machine is in the stowed position. Ensure the hydraulic oil has warmed to operating temperature before checking the reservoir.

1. Open the hydraulic compartment door and locate the hydraulic reservoir (1).
2. Locate the lines indicating the maximum and minimum levels of hydraulic oil (2 and 3) in the reservoir. Ensure the level of oil is between the two lines.
3. If the level of oil in the reservoir is below the minimum level (3), more oil is needed. Wipe all dirt and debris from the filler/filter cap (4) and surrounding area.
4. Remove filler cap and add proper grade of oil. Fill until oil level is close to the maximum level (2). Do not overfill.

**NOTE:** Take precautions so impurities (dirt, water, etc.) cannot enter the hydraulic system while filler/filter cap is removed.

**NOTE:** Recommended lubrication intervals are based on machine operations under normal conditions. For machines used in multi-shift operations and/or exposed to hostile environments or conditions, lubrication frequencies must be increased accordingly.

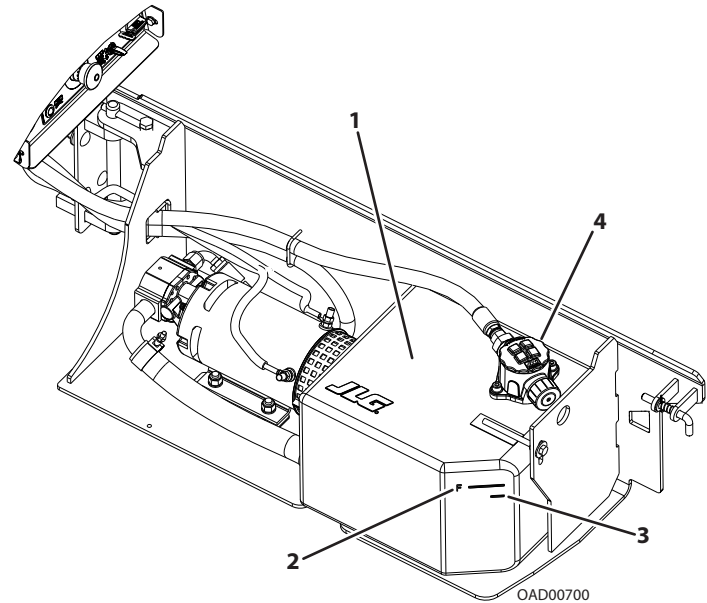

### Battery Maintenance and Safety Practices

**NOTE:** These instructions are for unsealed (wet) batteries only. If machine is equipped with sealed batteries, no maintenance is required other than cleaning corroded battery terminals.



**ENSURE THAT BATTERY ACID DOES NOT COME INTO CONTACT WITH SKIN OR CLOTHING. WEAR PROTECTIVE CLOTHING AND EYEWEAR WHEN WORKING WITH BATTERIES. NEUTRALIZE ANY BATTERY ACID SPILLS WITH BAKING SODA AND WATER.**

**BATTERY ACID RELEASES AN EXPLOSIVE GAS WHILE CHARGING, ALLOW NO OPEN FLAMES, SPARKS OR LIGHTED TOBACCO PRODUCTS IN THE AREA WHILE CHARGING BATTERIES. CHARGE BATTERIES ONLY IN A WELL-VENTILATED AREA.**

**ADD ONLY DISTILLED WATER TO BATTERIES. WHEN ADDING DISTILLED WATER TO THE BATTERIES, A NON-METALLIC CONTAINER AND/OR FUNNEL MUST BE USED.**

Check the electrolyte level of the batteries often and add only distilled water when required. When fully charged, battery fluid level should be 1/8" below vent tubes.

- DO NOT fill to bottom of vent tubes.
- DO NOT allow fluid level to go below the top of the plates when charging or operating.

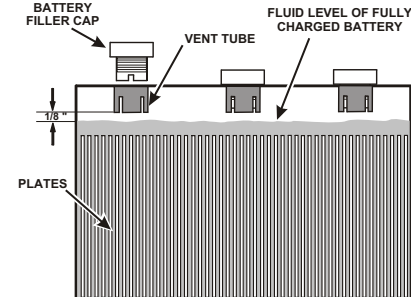

### Battery Quick-Disconnect

The battery quick-disconnect allows all machine power to be easily disconnected at the batteries without removing battery cables from the battery posts. To disconnect power, locate the RED quick-disconnect connector on top of the batteries inside the battery compartment and pull halves apart.

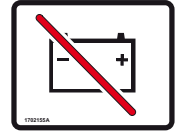

### 6.7 TIRE WEAR AND DAMAGE

The tire and rim assemblies installed on machines have been approved by the tire manufacturer for applications in which those products are intended to be used. The tire and rims installed on each product model have been designed for stability requirements, which consist of track width, tire compound, and load capacity. Tire changes such as rim width, centerpiece location, larger or smaller diameter, tire compound, etc., without written manufacturers approval, could result in an unsafe condition regarding stability.

The tires and rims installed on machines are to be inspected as part of the walk-around inspection. JLG requires that the walk-around inspection be performed at each operator change during a shift and at each shift change.

### Wheel and Tire Replacement

JLG recommends that any replacement tire be the same size and brand as originally installed on the machine or offered by JLG as an approved replacement. Refer to the JLG Parts Manual for the part number of the approved tires for a particular machine model.

If any of the following is discovered during tire inspection, measures must be taken to remove the JLG product from service immediately. Arrangements must be made for replacement of the tire(s) or tire assembly(s).

If the overall diameter of the tire is less than 15.55 in (395 mm) minimum or if any uneven wear is discovered, both tires/wheels on the same axle must be replaced.

A tire with significant damage in the tread area or sidewall requires immediate evaluation before placing the machine into service. If a cut, tear, chunk, or other discrepancy exceeds any one or more of the following dimensions, the tire must be replaced:

- 3.0 in (76 mm) long
- 0.75 in (19 mm) wide
- 0.75 in (19 mm) deep
- If the metal wheel is visible at any point through the tread area of the tire
- If more than one discrepancy exists in any quadrant of the wheel (within 90 degrees of one another)

## Wheel Installation

It is extremely important to apply and maintain proper wheel mounting torque.

### **⚠ WARNING**

**WHEEL SLOTTED NUTS MUST BE INSTALLED AND MAINTAINED AT THE PROPER TORQUE TO PREVENT LOOSE WHEELS, A BROKEN NUT, AND POSSIBLE SEPARATION OF WHEEL FROM THE AXLE.**

Tighten the slotted nuts to the proper torque to prevent wheels from coming loose. Use a torque wrench to tighten the slotted nuts. The proper procedure for attaching wheels is as follows:

1. If not already installed, install shaft key (5) to shaft and align with wheel keyway, install wheel and hub (3) onto tapered shaft (4).
2. Start slotted nut (1) by hand to prevent cross threading. DO NOT use a lubricant on threads or nut.
3. Torque the slotted nut to 150 ft. lb. (203 Nm).
4. Install cotter pin (2), if hole in slots do not align with cotter pin hole on the tapered shaft, continue to turn nut clockwise to align nut with hole. Do not loosen to align hole.

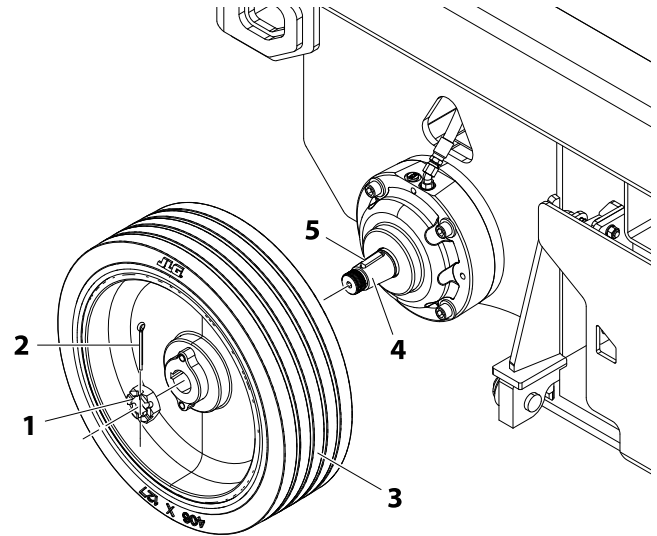

- |                           |                  |
|---------------------------|------------------|
| 1. Slotted Nut            | 4. Tapered Shaft |
| 2. Cotter Pin             | 5. Shaft Key     |
| 3. Wheel and Hub Assembly |                  |

## 6.8 DECAL INSTALLATION

### Diagram

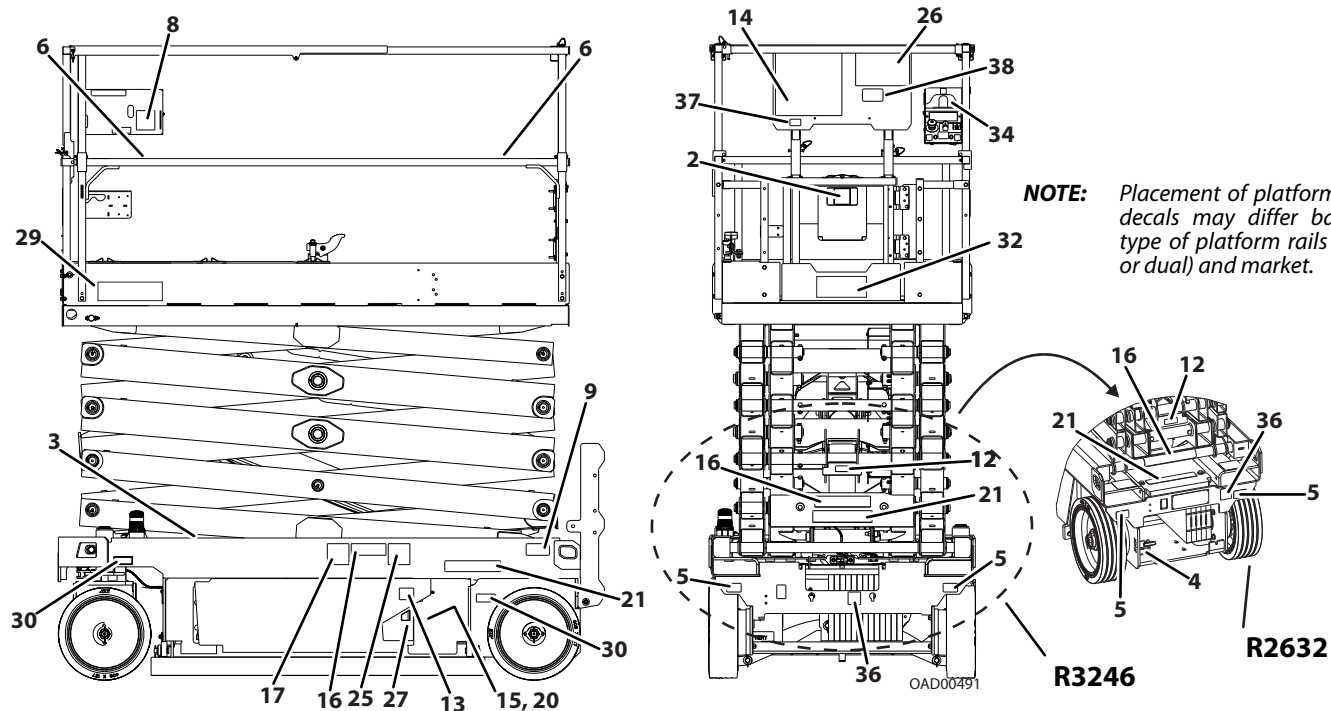

## SECTION 6 - SPECIFICATIONS AND OPERATOR MAINTENANCE

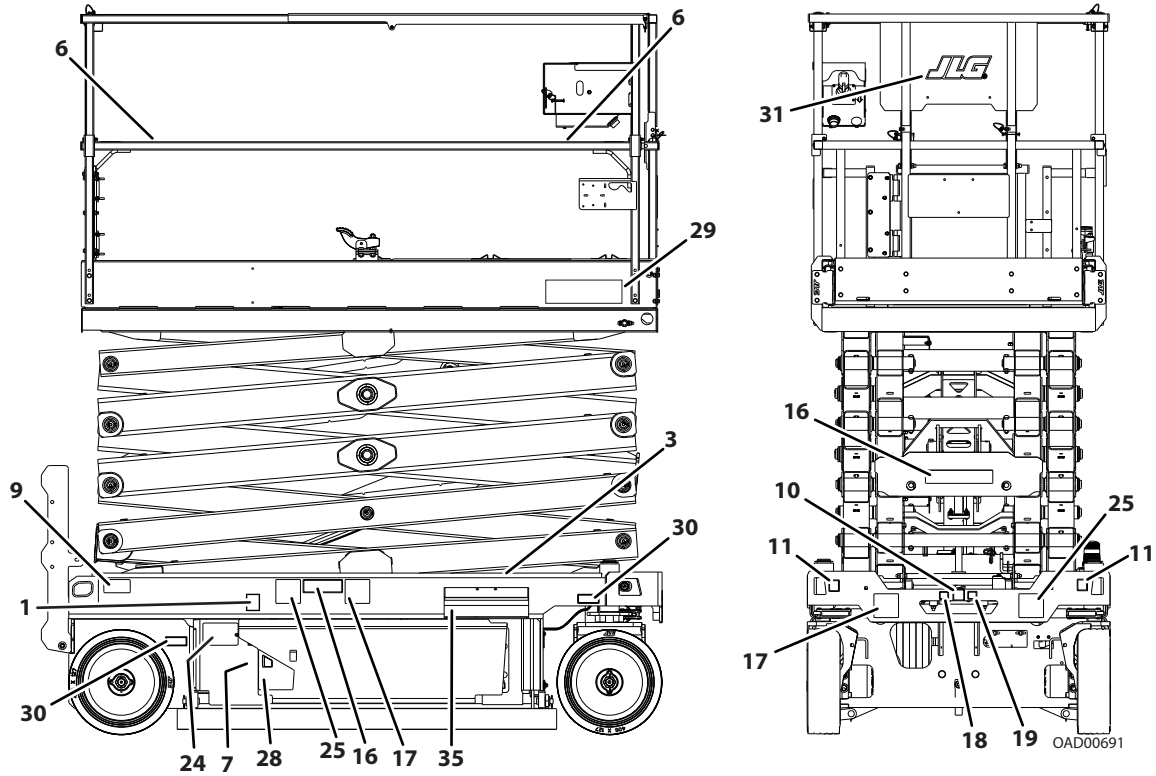

## SECTION 6 - SPECIFICATIONS AND OPERATOR MAINTENANCE

### Decals

ITEM	ENGLISH (1001238014-C)	KOREAN (1001238015-C)	CHINESE (1001238016-C)	SPA/POR (1001238017-B)	ENG/SPA (1001238018-B)	ENG/FRE (1001238019-B)	CE (1001238020-C)	AUS/Japan (1001238021-C)
1	1701504	1701504	1701504	1701504	1701504	1701504	1701504	1701504
2	1701640	1701640	1701640	1701640	1701640	1701640	1701640	1701640
3	1703819	1703819	1703819	1703819	1703819	1703819	1703819	1703819
4	1001248126	1001248126	1001248126	1001248126	1001248126	1001248126	1001248126	1001248126
5	1704016	1704016	1704016	1704016	1704016	1704016	1704016	1704016
6	1704277	1704277	1704277	1704277	1704277	1704277	1704277	1704277
7	1704412	1704412	1704412	1704412	1704412	1704412	1704412	1704412
8	1001132359	1001132359	1001132359	1001132359	1001132359	1001132359	1001132359	1001132359
9	1001162864	1001162864	1001162864	1001162864	1001162864	1001162864	1001162864	1001162864
10	1001212290	1001212290	1001212290	1001212290	1001212290	1001212290	1001212290	1001212290
11	1001212291	1001212291	1001212291	1001212291	1001212291	1001212291	1001212291	1001212291
12	1001237899	1001237899	1001237899	1001237899	1001237899	1001237899	1001237899	1001237899
13	1702155	1702155	1702155	1702155	1702155	1702155	1702155	1702155
14	1703816	1001162115	1705195	1704699	1704691	1704684	--	--
15	1001146794	1001146794	1001146794	1001146794	1001146794	1001146794	1001146795	1001146794
16	1001211777	1001215751	1001215752	1001216650	1705316	1705311	1705673	1705673
17	1001211779	1001211779	1001211779	1001215748 (SPA)	1001211779	1001211779	1705671 (5)	1705671 (5)
18	1001212292	1001212292	1001212292	1001212292	1001212292	1001212292	1001212292	1001212292
19	1001212293	1001212293	1001212293	1001212293	1001212293	1001212293	1001212293	1001212293
20	1001237538	1001237538	1001237538	1001237538	1001237538	1001237538	1001237538	1001237538
21	1703813	1707022	1704344	1704341	1704339	1704340	1705670	1705670



## SECTION 6 - SPECIFICATIONS AND OPERATOR MAINTENANCE

ITEM	ENGLISH (1001238014-C)	KOREAN (1001238015-C)	CHINESE (1001238016-C)	SPA/POR (1001238017-B)	ENG/SPA (1001238018-B)	ENG/FRE (1001238019-B)	CE (1001238020-C)	AUS/Japan (1001238021-C)
22	--	--	--	--	--	--	--	--
23	--	--	--	--	--	--	--	--
24	1001223055	1001224048	1001224051	1001224052	1001224049	1001223971	--	--
25	--	1001215750	1001215747	1001216648	1001215748	1001215749	--	--
26	1001237115	1001237115	1001237115	1001237115	1001237115	1001237115	1001237115	1001237115
27	1001255105	1001255105	1001255105	1001255105	1001255105	1001255105	1001255105	1001255105
28	1001255104	1001255104	1001255104	1001255104	1001255104	1001255104	1001255104	1001255104
29	1001257174 (R2632) 1001257175 (R3246)	1001257174 (R2632) 1001257175 (R3246)	1001257174 (R2632) 1001257175 (R3246)	1001257174 (R2632) 1001257175 (R3246)	1001257174 (R2632) 1001257175 (R3246)	1001257174 (R2632) 1001257175 (R3246)	1001257174 (R2632) 1001257175 (R3246)	1001257174 (R2632) 1001257175 (R3246)
30	1706312	1706312	1706312	1706312	1706312	1706312	1706312	1706312
31	1705754	1705754	1705754	1705754	1705754	1705754	1705754	1705754
32	1001256676	1001256676	1001256676	1001256676	1001256676	1001256676	1001256676	1001256676
33	--	--	--	--	--	--	--	--
34	1001218285	1001218285	1001218285	1001218285	1001218285	1001218285	1001218285	1001218285
35	1001209682	1001209682	1001209682	1001209682	1001209682	1001209682	1001209682	1001209682
36	--	--	--	--	--	--	1001173703 (Russia/CIS Only)	--
37	1001228370	--	--	--	--	1001228370	--	--
38	1001231801	--	--	--	--	1001231801	--	--

### 6.9 DIAGNOSTIC TROUBLE CODES (DTC)

#### **NOTICE**

THE DTC CODES LISTED IN THE FOLLOWING TABLE IS NOT A COMPLETE LISTING OF MACHINE DTC CODES. THIS LISTING SHOWS ONLY THOSE DTCS THAT AN OPERATOR MAY BE ABLE TO CORRECT DUE TO OPERATING ERROR.

The DTC table following is sorted in groups by the first two digits, these digits represent the number of flashes the system distress indicator lamp will flash on the platform indicator panel when a fault occurs.

The more detailed three to five digit code numbers in the DTC column of the following tables are only indicated on a JLG hand-held diagnostic analyzer connected to the machine, or on the Ground Control Station - MDI indicator, if equipped.

To troubleshoot multiple DTCs, start with the DTC with the higher first two digits.

**If a correction is made during a check, conclude the check by cycling the machine power off then back on, using the emergency stop switch.**

#### **NOTICE**

**SHOULD A FAULT OCCUR WHICH CANNOT BE CORRECTED BY THE OPERATOR, THE PROBLEM MUST BE REFERRED TO A QUALIFIED JLG MECHANIC.**

## SECTION 6 - SPECIFICATIONS AND OPERATOR MAINTENANCE

DTC	Help Message	Alarm	Flash Code	Action	Trigger
001	EVERYTHING OK	None	None	· No Motion restrictions	• Platform Mode and no Faults are active.
002	GROUND MODE OK	None	None	· No Motion restrictions	• Ground Mode and no Faults are active.
003	ALARM SOUNDING – TILTED & ABOVE ELEVATION	PF: Continuous	None	· No Motion restrictions	• Platform is elevated and chassis is not level
004	DRIVING AT CUTBACK – ABOVE ELEVATION	None	None	· DriveState = CREEP	• Platform is elevated and machine is in drive mode of operation
005	DRIVE & LIFT UP PREVENTED TILTED & ELEVATED	PF: Continuous	None	• DriveState = PREVENTED • LiftUpState = PREVENTED	• Driving and lift up are not possible since the platform is elevated and the chassis is not level.
006	LIFT UP PREVENTED – MAX HEIGHT ZONE A	None	None	• LiftUpState = PREVENTED	• The vehicle has reached the maximum height allowed by the Indoor/Outdoor selection and further lift up motion is not possible.
007	DRIVING AT CUTBACK – POTHOLE STILL ENGAGED	None	None	• DriveState = CREEP	<ul style="list-style-type: none"> <li>• While stowed, drive speed is reduced (due to lower ground clearance) since the control system detected that the pot-hole protection mechanism is deployed (failed to retract).</li> <li>• Clear the obstacle blocking the pot-hole protection mechanism, repair the mechanical problem, re-adjust the pot-hole limit switches, or repair the wiring to correct the problem.</li> <li>• Alternately, there may be difficulty with the Elevation Angle Sensor that causes the Control System to improperly believe the platform is stowed.</li> </ul>

## SECTION 6 - SPECIFICATIONS AND OPERATOR MAINTENANCE

DTC	Help Message	Alarm	Flash Code	Action	Trigger
008	FUNCTIONS LOCKED OUT – SYSTEM POWERED DOWN	None	None	<ul style="list-style-type: none"> <li>• Enter SafeMode</li> <li>• LiftDownState = PREVENTED</li> </ul>	<ul style="list-style-type: none"> <li>• A period of time elapsed without activity and the Control System entered a low-power state to preserve battery charge (2 hours). Cycle the Ground EMS in GroundMode or the Platform EMS in PlatformMode to re-enable the vehicle.</li> <li>• Two hours (10 minutes if GroundMode) without Drive Forward, Drive Reverse, Lift Up, Lift Down, Steer Left, or Steer Right.</li> <li>• Timer resets if user changes PlatformMode/GroundMode</li> </ul>
009	DRIVE PREVENTED – ELEVATED ABOVE DRIVE CUTOUT HEIGHT	None	None	<ul style="list-style-type: none"> <li>• DriveState = PREVENTED</li> </ul>	<ul style="list-style-type: none"> <li>• The Drive Cutout functionality is enabled, and the Platform is Elevated above the Calibrated Cutout Height.</li> </ul>
211	POWER CYCLE	None	2_1	<ul style="list-style-type: none"> <li>• No Motion restrictions</li> </ul>	<ul style="list-style-type: none"> <li>• This Help Message is issued at each power-up. This serves to indicate which messages have been recorded in the failure log since the last power-up event.</li> </ul>
212	KEYSWITCH FAULTY	None	2_1	<ul style="list-style-type: none"> <li>• Force to GroundMode</li> </ul>	<ul style="list-style-type: none"> <li>• Both the Ground Select and Platform Select signals are energized, which means there is an issue with the keyswitch or one of the lines are shorted to battery.</li> </ul>
221	FUNCTION PROBLEM – HORN PERMANENTLY SELECTED	None	2_2	<ul style="list-style-type: none"> <li>• Horn Prevented</li> </ul>	<ul style="list-style-type: none"> <li>• Horn Switch in the Platform Control Box was closed during power-up. Release or repair the switch to clear the message.</li> </ul>
2210	TRIGGER CLOSED TOO LONG WHILE IN NEUTRAL	None	2_2	<ul style="list-style-type: none"> <li>• TriggerState = FALSE therefore</li> <li>• DriveState = PREVENTED</li> <li>• LiftUpState = PREVENTED</li> <li>• LiftDownState = PREVENTED</li> </ul>	<ul style="list-style-type: none"> <li>• Trigger Switch on the Platform Control Box was closed for more than five seconds while the Joystick (accelerator) was in the neutral position (centered). Release switch or repair the switch / wiring to clear the difficulty.</li> </ul>
222	FUNCTION PROBLEM – INDOOR / OUTDOOR PERMANENTLY SELECTED	None	2_2	<ul style="list-style-type: none"> <li>• Previously selected Indoor / Outdoor Mode maintained</li> </ul>	<ul style="list-style-type: none"> <li>• Indoor / Outdoor Switch in the Platform Control Box was closed during power-up. Release or repair the switch to clear the message.</li> </ul>

## SECTION 6 - SPECIFICATIONS AND OPERATOR MAINTENANCE

DTC	Help Message	Alarm	Flash Code	Action	Trigger
223	FUNCTION PROBLEM – DRIVE & LIFT ACTIVE TOGETHER	None	2_2	<ul style="list-style-type: none"> <li>• MoveState = LIFT</li> <li>• DriveState = PREVENTED</li> <li>• LiftUpState = PREVENTED</li> <li>• LiftDownState = PREVENTED</li> </ul>	<ul style="list-style-type: none"> <li>• The Drive - Lift Selector Switch indicates that both functions are selected simultaneously. Repair the wiring or switch to clear the message.</li> </ul>
2232	FUNCTION PROBLEM – DRIVE & LIFT BOTH OPEN	None	2_2	<ul style="list-style-type: none"> <li>• MoveState = LIFT</li> <li>• DriveState = PREVENTED</li> <li>• LiftUpState = PREVENTED</li> <li>• LiftDownState = PREVENTED</li> </ul>	<ul style="list-style-type: none"> <li>• In PlatformMode, the Drive - Lift Selector Switch indicates neither function is selected. Repair wiring or switch to clear the message.</li> </ul>
224	FUNCTION PROBLEM – STEER LEFT PERMANENTLY SELECTED	None	2_2	<ul style="list-style-type: none"> <li>• DriveState = PREVENTED</li> </ul>	<ul style="list-style-type: none"> <li>• Steer Left Switch in the Platform Control Box was closed during power-up. Release or repair the switch to clear the message.</li> </ul>
225	FUNCTION PROBLEM – STEER RIGHT PERMANENTLY SELECTED	None	2_2	<ul style="list-style-type: none"> <li>• DriveState = PREVENTED</li> </ul>	<ul style="list-style-type: none"> <li>• Steer Right Switch in the Platform Control Box was closed during power-up. Release or repair the switch to clear the message.</li> </ul>
228	FUNCTION LOCKED OUT – ACCELERATOR NOT CENTERED	None	2_2	<ul style="list-style-type: none"> <li>• DriveState = PREVENTED</li> <li>• LiftUpState = PREVENTED</li> <li>• LiftDownState = PREVENTED</li> </ul>	<ul style="list-style-type: none"> <li>• Selected function (Drive or Lift) is not allowed because the joystick (accelerator) was not centered at power-up. Return joystick to center momentarily.</li> </ul>
229	FUNCTION PROBLEM – TRIGGER PERMANENTLY CLOSED	None	2_2	<ul style="list-style-type: none"> <li>• DriveState = PREVENTED</li> <li>• LiftUpState = PREVENTED</li> <li>• LiftDownState = PREVENTED</li> </ul>	<ul style="list-style-type: none"> <li>• Trigger Switch in the Platform Control Box was closed at power-up. Release switch or repair the switch / wiring to clear the difficulty.</li> </ul>
231	FUNCTION PROBLEM – LIFT PERMANENTLY SELECTED	None	2_3	<ul style="list-style-type: none"> <li>In GroundMode then</li> <li>• LiftUpState = PREVENTED</li> <li>• LiftDownState = PREVENTED</li> </ul>	<ul style="list-style-type: none"> <li>• Lift Switch (Up or Down) in the Ground Control Box was closed during power-up. Release or repair the switch to clear the message.</li> </ul>
232	GROUND LIFT UP/DOWN ACTIVE TOGETHER	None	2_3	<ul style="list-style-type: none"> <li>In GroundMode then</li> <li>• LiftUpState = PREVENTED</li> <li>• LiftDownState = PREVENTED</li> </ul>	<ul style="list-style-type: none"> <li>• In GroundMode, the control system has detected the Lift Up and Down are active simultaneously. Check the Lift Switch and associated wiring in the Ground Control Box.</li> </ul>
242	AMBIENT TEMPERATURE SENSOR – OUT OF RANGE HIGH	PF: Continuous	2_4	<ul style="list-style-type: none"> <li>• Drive and Lift Restrictions</li> </ul>	<ul style="list-style-type: none"> <li>• The temperature as communicated by the temperature/tilt sensor is greater than 185° F (85° C).</li> </ul>

## SECTION 6 - SPECIFICATIONS AND OPERATOR MAINTENANCE

DTC	Help Message	Alarm	Flash Code	Action	Trigger
253	DRIVE PREVENTED – CHARGER CONNECTED	None	2_5	• DriveState = PREVENTED	• Driving is not possible since the vehicle is charging.
254	DRIVE & LIFT UP PREVENTED – CHARGER CONNECTED	None	2_5	• DriveState = PREVENTED • LiftUpState = PREVENTED	• Driving and Lifting are not possible since the vehicle is charging and it is configured to prevent all motion.
255	PLATFORM OVERLOADED	PF: 5000ms ON/ 2000ms OFF  GND: 5000ms ON/2000ms OFF	2_5	• Drive and Lift Restrictions	• While the Load Sensing System is enabled, the Platform Load measured by the Load Sensing System is excessive. Functions from Platform Control Station are prevented, and functions from Ground Control may be prevented, depending on machine configuration. • Refer to LSS functionality for Lift and Drive restrictions.
256	DRIVE PREVENTED – POTHOLE NOT ENGAGED	PF: 500ms On/ 500ms Off  GND: 500ms On/ 500ms Off	2_5	• DriveState = PREVENTED	• While elevated, driving is not possible since the control system detected that the pot-hole protection mechanism failed to deploy. Clear the obstacle blocking the pot-hole protection mechanism, repair the mechanical problem, re-adjust the pot-hole limit switches, or repair the wiring to correct the problem. • Alternately, there may be difficulty with the Elevation Angle Sensor that causes the Control System to improperly believe the platform is elevated.
2568	TEMPERATURE CUTOUT ACTIVE - AMBIENT TEMPERATURE TOO LOW	If TransportMode = TRUE PF: Continuous  If TransportMode = FALSE PF: OFF	2_5	• Drive and Lift Restrictions	• The temperature as communicated by the temperature sensor located on the temperature/tilt sensor is less than or equal to {PERSONALITIES->TEMP CUTOUT->CUTOUT SET} • (See Low Temperature Cutout Functionality) • This DTC shall not be displayed in GroundMode, and no restrictions shall be implemented.
421	POWER MODULE TOO HOT - PLEASE WAIT	None	4_2	• DriveState = PREVENTED • LiftUpState = PREVENTED	• Heatsink temperature above 203°F (95° C). • <b>Possible Cause:</b> • Controller is operating in an extreme environment. • Excessive load on vehicle. • Improper mounting of controller

## SECTION 6 - SPECIFICATIONS AND OPERATOR MAINTENANCE

DTC	Help Message	Alarm	Flash Code	Action	Trigger
4235	POWER MODULE TOO HOT - REDUCED OPERATION	None	4_2	<ul style="list-style-type: none"> <li>• DriveState = CREEP</li> <li>• LiftUpState = CREEP</li> </ul>	<ul style="list-style-type: none"> <li>• Heatsink temperature exceeded 185° F (85° C).</li> <li>• <b>Effect:</b> Reduced drive and brake torque.</li> <li>• <b>Possible Cause:</b></li> <li>• Controller is performance-limited at this temperature.</li> <li>• Controller is operating in an extreme environment.</li> <li>• Excessive load on vehicle</li> <li>• Improper mounting of controller.</li> </ul>
4236	POWER MODULE TOO COLD - MODULE SHUTDOWN	None	4_2	<ul style="list-style-type: none"> <li>• DriveState = PREVENTED</li> <li>• LiftUpState = PREVENTED</li> </ul>	<ul style="list-style-type: none"> <li>• Heatsink temperature below -40° F (-40° C).</li> <li>• <b>Possible Cause:</b></li> <li>• Controller is operating in an extreme environment.</li> </ul>
426	MASTER MODULE TEMPERATURE – OUT OF RANGE	None	4_2	<ul style="list-style-type: none"> <li>• Normal operation</li> </ul>	<ul style="list-style-type: none"> <li>• The Ground Module's internal temperature sensor is out of range. (&lt; 104° F (40° C) or &gt; 302° F (150° C)</li> </ul>
441	BATTERY VOLTAGE TOO LOW – SYSTEM SHUTDOWN	None	4_4	<ul style="list-style-type: none"> <li>• SafeMode</li> <li>• LiftDownState = PREVENTED</li> </ul>	<ul style="list-style-type: none"> <li>• Battery Voltage(VBAT) momentarily dropped below 14.5V when using flooded lead-acid batteries, or 16.0V when using AGM batteries. With a low battery charge, this can occur during heavy current demand due to Drive, Steer, or Lift Up. Recharge batteries or check for damaged batteries, sulfated batteries, or poor power connections.</li> </ul>
442	BATTERY VOLTAGE TOO HIGH – SYSTEM SHUTDOWN	None	4_4	<ul style="list-style-type: none"> <li>• Enter SafeMode</li> <li>• LiftDownState = MAX</li> </ul>	<ul style="list-style-type: none"> <li>• The Ground Module measured excessively high battery voltage (VBAT) (&gt;32.0V) and de-energized the Main Line Contactor and Battery Relay to protect system devices and was unable to bring voltage down to normal operating range. This may be due to improper battery charging or incorrect voltage batteries being used.</li> </ul>
4421	LOGIC SUPPLY VOLTAGE OUT OF RANGE HIGH	None	4_4	<ul style="list-style-type: none"> <li>• Enter SafeMode</li> <li>• LiftDownState = MAX</li> </ul>	<ul style="list-style-type: none"> <li>• The Ground Module's VSW voltage was measured to be more than 32V. This may be caused by loose battery terminal, severely discharge batteries, a damaged battery, or an improper wire harness connection.</li> </ul>

## SECTION 6 - SPECIFICATIONS AND OPERATOR MAINTENANCE

DTC	Help Message	Alarm	Flash Code	Action	Trigger
4424	POWER MODULE VOLTAGE TOO LOW - MODULE SHUTDOWN	None	4_4	<ul style="list-style-type: none"> <li>• DriveState = PREVENTED</li> <li>• LiftUpState = PREVENTED</li> </ul>	<ul style="list-style-type: none"> <li>• <b>Severe B+ Undervoltage Set:</b> Capacitor bank voltage dropped below Severe Undervoltage limit with FET bridge enabled.</li> <li>• <b>Effect:</b> Reduced Drive Torque</li> <li>• <b>Possible Cause:</b> <ul style="list-style-type: none"> <li>• Battery menu parameters are misadjusted</li> <li>• Non-controller system drain on battery</li> <li>• Battery resistance too high</li> <li>• Battery disconnected while driving</li> <li>• Blown B+ fuse or main contactor not closed</li> </ul> </li> </ul>
4475	POWER MODULE - BDI FAULT	None	4_4	<ul style="list-style-type: none"> <li>• DriveState = PREVENTED</li> <li>• LiftUpState = PREVENTED</li> </ul>	<ul style="list-style-type: none"> <li>• <b>Pump BDI Fault Set:</b> BDI Percentage charge at 0% when the pump was activated.</li> <li>• <b>Effect:</b> ShutdownPump</li> <li>• <b>Possible Cause:</b> <ul style="list-style-type: none"> <li>• Battery is fully discharged</li> <li>• BDI parameters are mis-tuned</li> </ul> </li> </ul>
4476	BATTERY VOLTAGE TOO HIGH – UNPLUG CHARGER	None	4_4	<ul style="list-style-type: none"> <li>• Enter SafeMode</li> <li>• LiftDownState = MAX</li> </ul>	<ul style="list-style-type: none"> <li>• The Ground Module momentarily measured excessively high battery voltage (VBAT) (&gt;32.0V) and entered SafeMode to protect system devices. This may be due to improper battery charging or incorrect voltage batteries being used.</li> </ul>
4477	BATTERY VOLTAGE TOO HIGH – FORCING DISCHARGE	None	4_4	<ul style="list-style-type: none"> <li>• Lift Down = PREVENTED</li> <li>• Lift Up = PREVENTED</li> <li>• Drive = PREVENTED</li> </ul>	<ul style="list-style-type: none"> <li>• The Ground Module momentarily measured excessively high battery voltage (VBAT) (&gt;32.0V) and entered SafeMode. This may be due to improper battery charging or incorrect voltage batteries being used.</li> </ul>











An Oshkosh Corporation Company

***Corporate Office  
JLG Industries, Inc.  
1 JLG Drive***

***McConnellsburg, PA 17233-9533 USA***

***☎ (717) 485-5161 (Corporate)***

***☎ (877) 554-5438 (Customer Support)***

***☎ (717) 485-6417***

***Visit our website for JLG Worldwide Locations.  
[www.jlg.com](http://www.jlg.com)***